



aerospace
climate control
electromechanical
filtration
fluid & gas handling
hydraulics
pneumatics
process control
sealing & shielding



Hydraulic Hoses, Fittings and Equipment

Catalogue



ENGINEERING YOUR SUCCESS.

Detailed table of Contents

Introduction

2 – 22

Technical Handbook

Hoses and Fittings Terminology – The basics

Aa-2 – Aa-8

Safe Hose Assemblies in 8 Steps

Aa-9 – Aa19

How to Order (Part number description)

Aa-20 – Aa-21

Hoses and Fittings Storage

Aa-22 – Aa-23

Safety Precaution

Aa-24 – Aa-25

Proactive Maintenance Programme

Aa-26

Technical Data

Ab-2 – Ab-45

Low Pressure Push-Lok

Push-Lok Hoses

B1a-1 – B1a-9

Fittings 82 series

B1b-1 – B1b-21

Assembly Instructions / Assembly Tools

B1b-22

Low Pressure Transportation + Hydraulic

Hoses

B2a-1 – B2a-11

Fittings 26 series

B2b-1 – B2b-11

Medium pressure

Parkrimp No-Skive Hoses

Ca-1 – Ca-32

Fittings 46 and 48 series

Cb-1 – Cb-48

High pressure

Hoses

Da-1 – Da-30

Fittings 70 series

Db-1 – Db-19

Fittings 71 series

Dc-1 – Dc-16

Fittings 73 series

Dd-1 – Dd-17

Fittings 76 series

De-1

Fittings 77 series

Df-1 – Df-16

Fittings 78 series

Dg-1 – Dg-15

Fittings 79 series

Dh-1 – Dh-6

Fittings S6 series

Di-1 – Di-3

Fittings VS series

Dj-1 – Dj-16

Fittings V4/V6/VB series

Dk-1 – Dj-28

Machines, Tooling, Accessories

Machines

Ea-1 – Ea-29

Accessories

Eb-1 – Eb-20

Assembly Instructions

Ec-1 – Ec-2

Crimp Charts

Ed-1 – Ed-13

Parker Hannifin –

the global leader and your partner



With annual sales exceeding \$12 billion, Parker Hannifin is the world's leading diversified manufacturer of motion and control technologies and systems, providing precision-engineered solutions for a wide variety of mobile, industrial and aerospace markets. Our products are vital to virtually everything that moves or requires control, including the manufacture and processing of raw materials, durable goods, infrastructure development and all forms of transport.

Within Parker's eight operating groups, the company's engineering expertise spans the core motion technologies – electromechanical, hydraulic and pneumatic – with a full complement of fluid handling, filtration, sealing and shielding, climate control, process control and aerospace technologies. The leader in “dry technology” for the fluid power industry, Parker's Fluid Connectors Group is your single source for high-quality tube fittings, hose and hose fittings, thermoplas-

tic tubing, brass fittings and valves, quickdisconnect couplings and assembly tools. The Fluid Connectors Group serves customers in a broad range of markets, including Aerial Lift, Agriculture, Bulk Chemical Handling, Construction Machinery, Food & Beverage, Fuel & Gas Delivery, Industrial Machinery, Medical, Mining, Mobile, Oil & Gas and Transportation. Products are available for shipment 24 hours a day, supported by 49 manufacturing facilities throughout the world, a global distribution

network and 25 company-owned stocking service centers. Our commitment to you is impeccable customer service. To meet your specific requirements, we offer a broad range of programs designed to reduce your overall operating costs, streamline manufacturing, improve productivity, manage inventory, enhance delivery and address safety and environmental issues. For value-added services that generate value-added solutions, team up with Parker!

Parker Hannifin –

opportunity through innovation in the world's most demanding markets



Worldwide availability

With more than 50,000 employees serving over 500,000 customers in almost 50 countries, Parker is literally everywhere you need us to be. By working with us, you have access to an integrated network of 300+ manufacturing plants, as well as 13,000 distributors and MRO outlets, and over 1,500 ParkerStores™. That's the kind of global network global businesses demand.

Flexibility

As the world's motion control expert, Parker offers you a complete range of proven, off-the-shelf products. These products deliver exceptional quality and durability, reducing costs and advancing performance.

Innovation

It's what drives us. Our mandate for continuous improvement leads us to partner with our customers to create solutions that are smaller, lighter, sustainable, more energy efficient, and highly reliable.

Hose Products Division Europe –

the market leader and your supplier of choice.



Put a bite on the braid.

Parker's world-recognized tiger mascot has represented the Parkrimp No-Skive hose assembly program since its introduction in 1980. In a contest originally held by our marketing department, the tiger was the winning suggestion over three others: a turtle (deemed "too slow"), an alligator ("not very good looking") and a shark ("too intimidating" particularly at the time of the release of the movie Jaws).

More than three decades later, the tiger graphic still supports the Parkrimp message everywhere, clearly symbolizing our unique, patented Parkrimp fittings with tapered steel teeth and our Parkrimp crimping machines. Their ability to eliminate hose cover skiving and achieve the metal-to-metal grip of factory assemblies revolutionized the process for markets worldwide. And today, it's the industry standard.

Pride in our products: At Parker, we believe the best fluid connector products for your operation are the ones that get the job done right. We offer the most comprehensive line of hoses, fittings, equipment and accessories you'll need. And if there's something you need that's not a standard product, we're able to design and manufacture it for you with ease.

You'll also benefit from our ultimate competitive advantage – our network of distribution outlets that can provide our products nearly anytime and anywhere. We strive to provide customers with local engineering, local products and local service.

Parker offers the largest selection of hoses plus more fitting sizes than any other manufacturer. You'll find a wide variety of hoses including braided, spiral and multi-purpose, and more than 4,500 Parkrimp fittings. Parker products have been designed, tested and approved to meet and exceed global standards.



The right product is available for your application, including hose that features a variety of abrasion-resistant cover choices, flexibility, a wide range of media compatibility and more – characteristics that make Parker the hose supplier of choice for customers that demand the most from their equipment.

Hose Products Division Europe –

a long history of providing premier customer service.

Our European division headquarters in Veniano, Italy is our precision-engineered-solution center for products, materials and processes, and is equipped with state-of-the-art

development, testing and performance technology. Hose Products Division Europe has 6 manufacturing locations dedicated to provide a quality product on time. Knowing that

uptime and productivity are major drivers in your business success, we proudly present this catalog outlining Parker's best-in-class hose products and services.



Low, Medium, High and Ultra Pressure Hose



Parkrimp® Hose Fittings



Parkrimp® Assembly Equipment

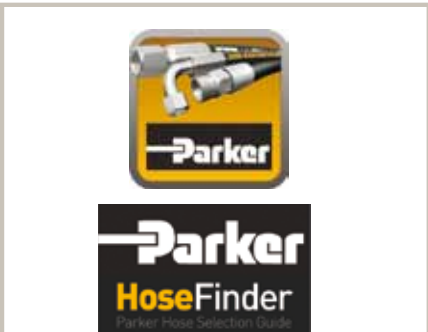

Mobile Phone Applications



Parker Tracking System



ParkerStore™ Onsite Container Program and Hose Doctor Service



Custom Hose Assemblies and Hose Fittings



Accessories

Compact Spiral™ Hose

The next evolution in hydraulic hose



Unprecedented 35.0 and 42.0 MPa hose performance in a compact design.

Compared with conventional spiral hose, Parker's Compact Spiral™ 787TC/797TC hose offers measurably greater advantages in routing and installation, product size and weight, inventory savings and much more. A world first, this development is the most significant advance in hydraulic hose since the introduction of Parker's No-Skive™ technology more than 25 years ago. Compact Spiral was developed in concurrence with the industry trend toward high-pressure hose manufactured to ISO specifications. Its many innovative and proprietary features set new standards in value and deliver hose characteristics deemed most important by OEM and aftermarket customers.

Just one series of hose ends, Parker's 77 series, covers all sizes of both 787TC and 797TC

Compact Spiral hoses, simplifying fitting selection and reducing hose-end inventory.



For more information about Compact Spiral hoses please refer to pages Da-14 and Da-16

Advancing the Industry

Compact Spiral hose delivers substantial performance and value for systems with high-pressure and high-impulse applications. These include large mobile equipment (off-highway, construction, forestry and mining), oil and gas applications and injection moulding equipment.



- 1/2 the bend radius of SAE 100R13/SAE 100R15
- 1/3 less effort to bend
- Nearly 30 % smaller O.D.
- Tested to 2,000,000 cycles
- High abrasion resistance
- Constant pressure
- Simplified fitting selection with 77 series in Interlock No-Skive design
- 25 % less hose weight

Bend Radius

Compact Spiral hose has half the bend radius of its SAE counterpart and a significantly smaller bend radius than the corresponding size of a Parker conventional spiral hose.

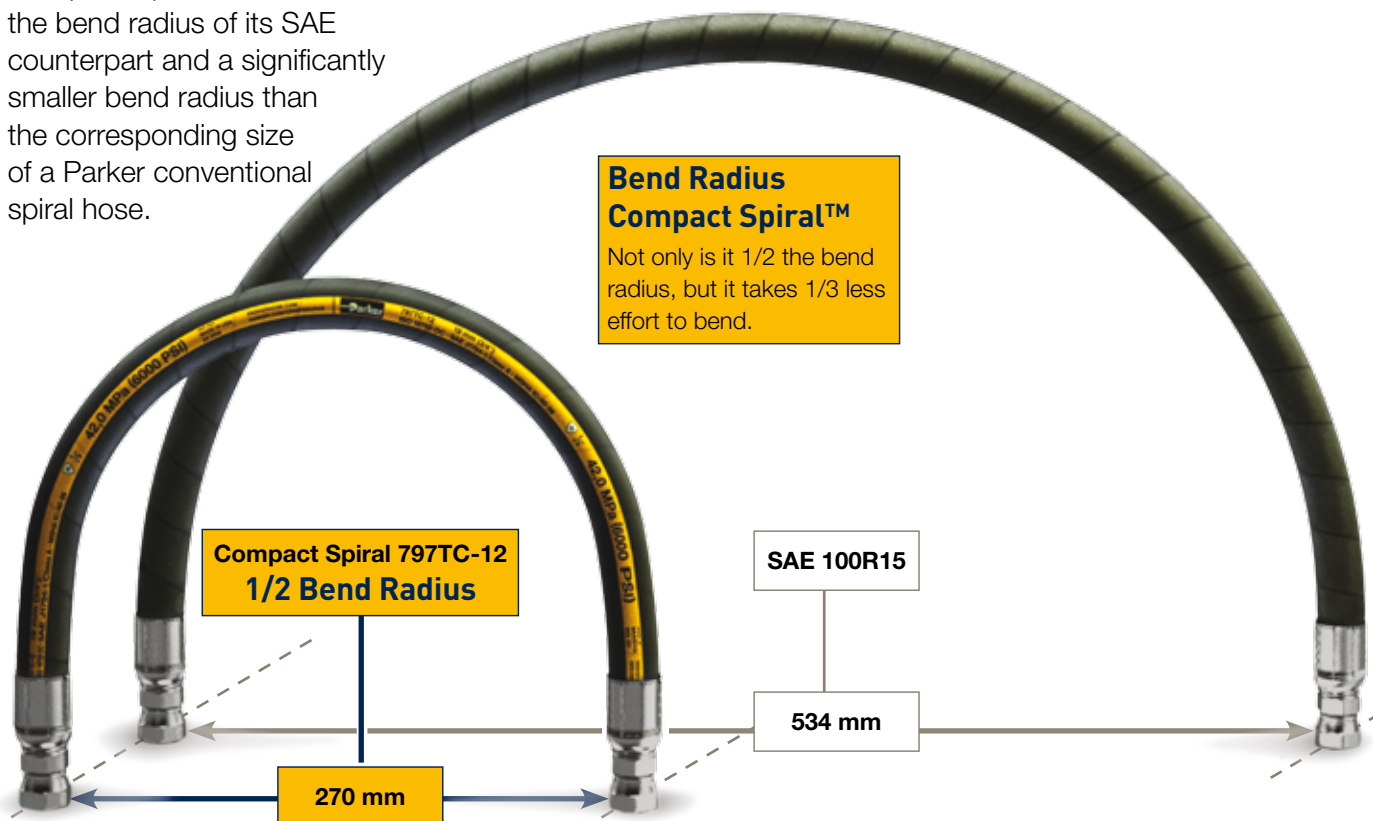

PowerLift 477

No-Skive 2 wire braided hose
for lifting and materials handling machines



The new **PowerLift 477** hose exceeds the EN required working pressure and the impulse cycles by a factor of two.

PowerLift is the ideal choice where lower weight, high pressure and tight bend radii are the driving factors influencing product selection. In addition to the standard **PowerLift** the **PowerLift 477ST** (Super Tough version) is also available. Ideal applications for the **PowerLift** hose are lifting and materials handling machines such as fork lift trucks, aerial lifts, cranes, telehandlers and lifting platforms.

The Super Tough cover increases the hose service life when hoses are exposed to extreme mechanical wear.

The Super Tough cover offers up to 450 times the abrasion resistance specified in the ISO 6945 standard for rubber hoses and provides the perfect alternative to expensive protective sleeves.



For more information about **PowerLift 477** please refer to pages **Ca-24** and **Ca-25**

RemoFlex 412

No-Skive 1 wire braided hose for pilot lines

RemoFlex 412 pilot line hose is a highly flexible 12.0 MPa constant pressure hose, ideally suited to the compact build requirements of modern equipment.

The combination of a highly abrasion and ozone resistant cover with its small outside diameter and the excellent fluid compatibility of the hose, through its nitrile inner tube, results in a pilot line hose that meets the demands of a wide customer base.

The **RemoFlex** 412 is ideal for many industrial and mobile applications especially in mobile construction equipment.



For more information about RemoFlex 412 please refer to page Ca-7

ParLock R50TC

Extra Strong 4 and 6 Spirals
50.0 MPa Isobaric Hose



For more information about
ParLock R50TC please refer
to page Da-30

Requirements for new hydrostatic drives are higher performances combined with the same hydraulic hose size but at improved velocity. With the new R50TC, this market requirement is fully met. Target markets for the new isobaric hose type R50TC are mobile hydraulic equipments with typically large construction or agricultural machines for applications such as hydrostatic drives or powering large bore cylinders where high flow rates, very high pressures and pulse rates are common. R50TC is a 4 spirals hose construction available in sizes -10, -12 and -16 (R50TC-16-SP4). The 6 spirals version is available in size -16 (type R50TC-16-SP6) and size -20. The most common connection types are 8000 PSI flange fittings.

Universal Push-to-Connect (UPTC) Assembly

The quick, simple, truly universal advantage for your product's design, manufacture and maintenance.

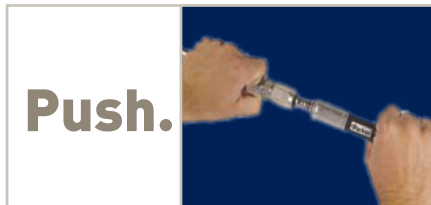

“Push, click, done” literally describes how quick and simple it is to achieve reliable leak-free connections with Parker's UPTC hose and tube assembly. Yet unprecedented speed and simplicity are only part of the total advantage.

Unlike other push-to-connect assembly designs, with Parker's patent-pending assembly you also achieve the “U”—that is, the genuine universality that ensures maximum compatibility and simple global sourcing. So from your equipment's design and production to its maintenance in the field, the UPTC assembly delivers savings never before possible, for everyone up and down the line.

Simply universal economics. Parker's universal, economic UPTC assembly utilizes standard O-Lok (ORFS) or EO (24° DIN cone) fitting bodies, and is suited for hydraulic hose (rubber or thermoplastic) and tube (inch or metric) assemblies. Also, while other push-to-connect couplings require changeovers to new male and female-end fitting designs, any existing Parker O-Lok or EO fitting system can be converted to a push-to-connect design. Thus, the number of UPTC connections is virtually unlimited.

Specifying Parker UPTC in product designs, particularly where space is limited, provides immediate savings in time and cost associated with the assembly process. Plus, UPTC reliability and simplicity extend to the field – helping to significantly reduce errors associated with rework and warranty claims. Here, its key advantages include standard wrench disassembly and no special connector needed for replacement of a damaged hose. Because the fitting body has not changed, a standard ORFS (or UPTC) assembly may be used for replacement, which greatly helps to minimize costly equipment downtime.



- Assembly time savings
- Guaranteed correct connection
- Elimination of hose twist
- Leak-free performance
- Wide range availability
- Easy design implementation
- Excellent field serviceability



For more information about UPTC please refer to intro-pages medium pressure and pages Cb-47 – Cb-48

Full Flange System

Provides full flange mounting option for Code 61 and 62 ports. System flexibility reduces inventory investment.



Reliability, Ease of Use, Performance, Flexibility

Parker's Hose Products Division introduces a one-piece flange option for Code 61 and Code 62 connections. The patent-pending design enables the flange to be attached to the hose after the hose fitting has been crimped to the hose.

Once the fitting is crimped, an SAE J 518 Code 61 or a Code 62 full flange can be attached using a highly tensile stainless steel retaining ring. The versatile fitting design enables greater flexibility by reducing the number of potential hose fittings in your inventory.

Hose Fittings

A variety of hose fittings are now available with more to come. Contact your Parker representative or go to www.parkerhose.com for the latest list of fittings.

- One-piece full flange connection
- Fittings are compatible with both Code 61 and Code 62 flanges
- All Code 61 sizes rated to 5000 psi

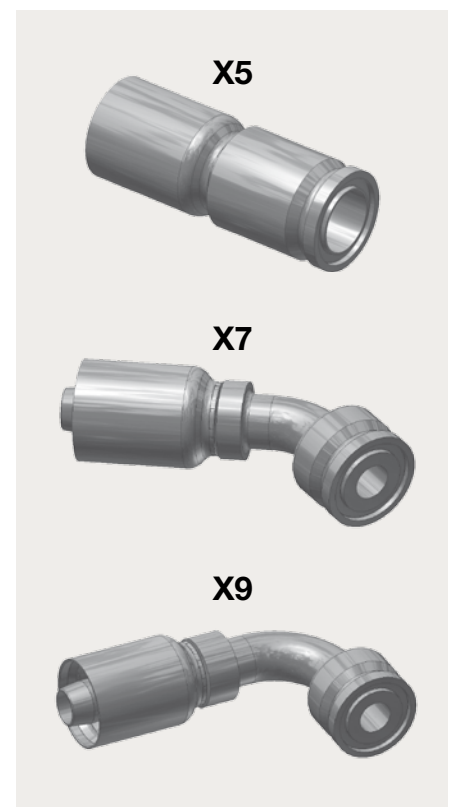

For more information about the Full Flange System please refer to intro-pages high pressure and Df-9 – Df-10, Dk-19 – Dk-20 and Eb-2

Non Standard and Customised Hose Fittings

Short runs or special applications are met by Parker's Rapid Service Unit (RSU)



The Rapid Service Unit (RSU) is part of the Manufacturing Unit Fittings of Hose Products Division Europe and is a dedicated unit for the manufacture of customised and prototype hose fittings. The unit is responsible for both checking the technical possibilities of the customer request from an engineering perspective as well as establishing the most economic production process. Because of close cooperation

between Parker's Manufacturing Units and the Parker Sales Companies (PSC) the Rapid Service Unit (RSU) can live up to its name by reacting, quoting and supplying rapidly.

After receiving the order, the RSU team will promptly and carefully process the order – from its receipt to the shipping of the fittings. For the production of such fittings, we have dedicated resources in a state-of-the-art manufacturing cell with CNC machinery and tools.



The Rapid Service Unit (RSU) can provide:

- Jump sizes
- Specific end configurations
- Specific drop lengths
- Fitting/tube combinations
- Customised prototypes
- Any batch size upwards from a single piece

Material options include steel, stainless steel, brass and special materials on request.

R35TC

Multispiral hose for increased pressure and flow rates

You are looking for a hose that delivers higher working pressures and more power through a higher flow rate? Or do you need a hose for heavy-duty applications with an abrasion-resistant cover for a longer service life?

Parker® R35TC completes the ParLock hose range with size -40 (I.D. 63.5 mm) and has been developed to increase the flow rate and to meet even the most challenging requirements of

various applications, such as high system pressure and high pulse rates.

Due to the enhanced hose diameters and in combination

with very high pressures, the flow rate can be increased, which eliminates the need of numerous pressure lines and results in a cost reduction for connectors.



For more information about R35TC please refer to page Da-26

Hybrid Push-Lok

The excellent combination of two basic materials

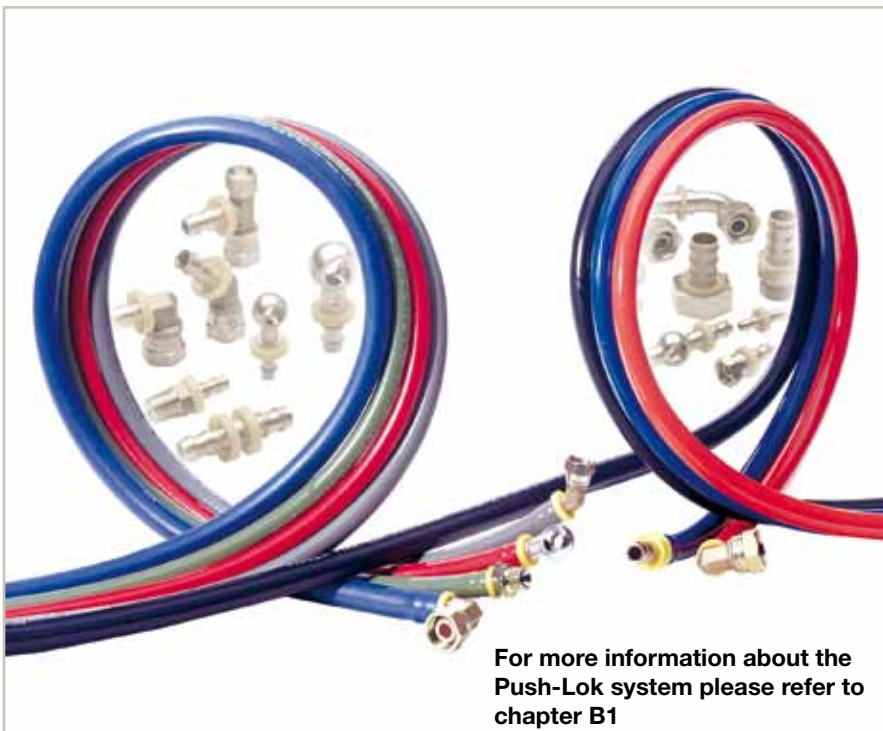

For more information about the Push-Lok system please refer to chapter B1

Through interactive development of both materials and manufacturing processes, the combination of polyurethane and synthetic elastomer has successfully resulted in the creation of a hybrid Push-Lok hose with exceptional technical properties.

- Hose cover made of high-quality polyurethane, featuring high resistance to welding spatter and abrasion.
- The highly tensile textile braid reinforcement ensures a firm grip of the hose onto the fitting and prevents it from pulling off.
- Synthetic elastomer core tube resistant to hydraulic fluids, dry air, water, water emulsions, etc.

Environmentally Friendly Plating Process

Chromium-6 has been classified in the EU Directive 67/548/EWG as Category 2, which means that this material may be carcinogenic under certain circumstances. Skin contact can bring about allergic reactions. Since 2006, all Parker steel fittings have been manufactured using trivalent chromate (chromium-6-free) plating. This new process enhances the

corrosion resistance of the fittings, and is more environmentally friendly than the previous hexavalent chromate plating. While the fitting function will not change, the fitting colour will. Fittings plated with trivalent chromate will be silver in colour, not gold. The Chromium-6 free plating process is implemented worldwide at all Parker facilities.

Chromium-6 Free



Where corrosion resistance is vital

stainless steel is the perfect solution

For pneumatic and hydraulic applications in demanding environments, your connection requirements will be met by Parker's range of stainless steel products. Parker offers a complete system of stainless steel products such as tubes, tube fittings

or 1- or 2-piece hose fittings for low, medium and high-pressure hydraulic hoses – everything from one source and approved by well known international classification bodies. It goes without saying that Parker's stainless steel components are produced

using superior quality stainless steel grade 1.457. Thanks to their resistance to corrosion and acids, all components are suitable for tough environments. However, some special applications require special materials and here you can rely on Parker as well – we have the resources to produce customised hose fittings for even the most demanding customer requirements.

Power in Stainless Steel

- Premier customer service
- Single-source solution
- Worldwide availability
- One team for all requirements
- Customized products
- Special materials
- Complementary design of tube & hose fittings



For more information about our stainless steel range please refer to catalogue CAT/4400.1/UK

We offer more

than just innovative products and solutions

Training in Hose Products

The extensive training programme of the Hose Products Division Europe contains theoretical and practical training sessions. Training takes place on a regular basis in the different Parker locations. Beside standard training Parker offers the possibility for customized in-house training. The main goal of Parker's product training is to acquire special knowledge about hose products, fittings, connectors and catalogues and will enable you to select efficiently and handle safely all Parker hose products.



For further information about the Hose Products Division Europe, please visit our website

www.parker.com/euro_hpd and for further information about other Parker products, please call

the European Product Information Centre free of charge on 0800 27 27 5374

Promotion Material about Parker Hose Products

If you are interested in promotion material about Parker Hose Products, please contact the relevant Parker Service Centre or visit the website www.parker.com/euro_hpd.

Under the menu bar „Literature“ a library can be found containing the current catalogues, sales & marketing bulletins/brochures, service manuals/user guides, certificates/approvals, technical articles, safety instructions.

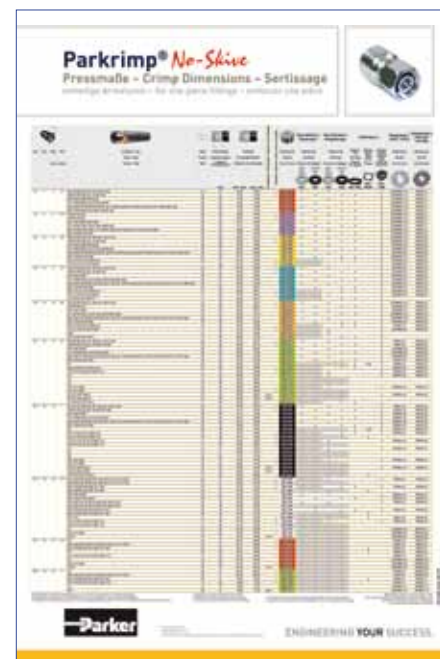

Value Added Services

to save customers' time and money

ParkerStore™

At Parker Hannifin, we're continually looking for ways to deliver more products, more efficiently.

The Global ParkerStore™ network enables Parker to provide:

- Prompt, efficient, professional in-store services while you wait
- Expert local services and support
- A safe, friendly and convenient shopping environment
- A greater range of parts options so you get exactly what you're looking for.



Customers trust ParkerStores to provide OEM and MRO customers with direct access to:

- Custom-made hydraulic hose assemblies and complementary products to support their applications and decrease their downtime

- Expert technical support
- Professional, personalized services, including 24/7/365 support
- The convenience, comfort and amenities of a local service provider.

ParkerStore™ Container Service



The ParkerStore container is a transportable workshop, providing on-site maintenance and product support for large construction projects such as roadworks, tunnels, railways, underground systems, etc. Provides an on-site product and hose replacement service. With this service on your site, you can reduce your downtime keeping your project on time and on budget!

HOSE DOCTOR®

Parker HOSE DOCTORS® are a network of independently-owned, mobile service technicians built around the commitment to identify and replace hose assemblies wherever their customers need them, with the fastest response times possible.

HOSE DOCTORS® are an extension of the worldwide Parker distribution network, coupling their service commitment with Parker products – the highest quality hoses and fittings available in the market today.



Kitting

Multiple components are supplied under a single part number

- Reduced number of suppliers
- Reduced stocks and no obsolete items
- Optimized management (stock and supplies)
- Simplified and optimised order handling
- Reduced assembly costs
- Greater productivity



Tech Services

Optimises the performance of your hydraulic and pneumatic circuits

- With Parker Tech Services involved, your time to market is shorter, which saves on development costs
- The 3 year no-leak guarantee enhances your reputation and lowers your warranty costs
- More reliable operation lowers your customer's operating costs
- More efficient performance and no-leak guarantee is beneficial to the environment
- Parker worldwide coverage ensures you can use the service and save costs wherever you are



Breadman

Lean logistics and delivery of Parker products and kits directly to the customer's assembly line, work stations or warehouse

- 100 % parts availability minimises downtime, increases production and reduces costs
- Elimination of stock checking reduces manpower and maintains production levels
- Daily delivery reduces inventory and overheads
- Electronic order processing eliminates paperwork and reduces administration costs



Parker® Tracking System Enterprise

Global asset tagging and identification system

The Parker® Tracking System Enterprise (PTS) is designed to help customers reduce vehicle or asset downtime through increases in the speed, timing and accuracy of necessary repairs. PTS provides a unique 8 digit identification code and bar code printed on a durable label for each hose assembly. PTS labels are specifically engineered to withstand harsh chemicals, temperatures, UV exposure and other challenging conditions.

- PTS captures, records and recalls unique hose assembly information – on demand
- Provides fast and accurate product identification to speed up replacement regardless of where the original assembly was made.
- Assembly can be replaced with only the 8 digit PTS ID number/bar code eliminating the need to remove hoses prior to replacement. This can provide critical machine uptime and enable more conveniently scheduled repair.
- PTS includes additional reporting tools to assist in continuous improvement programmes and preventative maintenance initiatives.

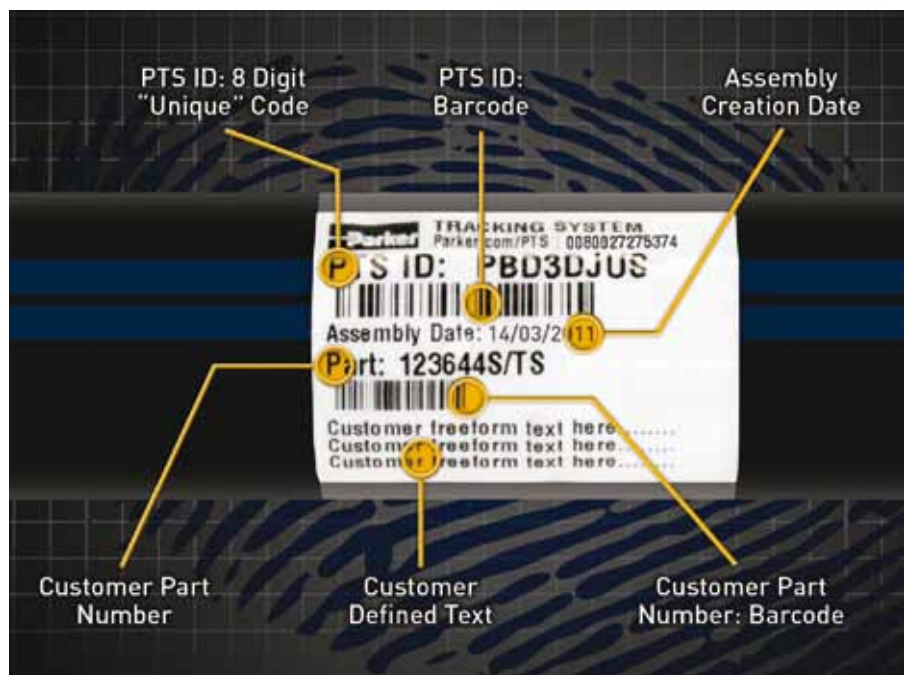

The benefits of working with Parker Hose

Bring the power of Parker to the palm of your hand.

Parker is committed to delivering customer service options to help you work smarter, faster, and better.

Need the latest? Go online. From complete product information on hose, to 3D-CAD models of our complete fitting line, you'll find everything you need at www.parkerhose.com.

And HoseFinder, our mobile app, makes it fast and convenient to search for hydraulic hose products and information on the go. The app features an abbreviated STAMP selection process to help you find what you need quickly and easily. Download yours today at www.hosefinder.com.

Whatever you do, visit our site often. It's the fastest and easiest way to keep up with changing technology and our ever expanding product offering.



HoseFinder^{2.0}
Parker Hose Selection Guide



- 1 Browse it.** It's easy to use.
- 2 STAMP it.** Use the STAMP search or browse the catalog to find the product you are looking for.
- 3 Search it.** Results include all the details you need to make an informed decision.
- 4 Find it.** Choose the "Find It" link and you'll be directed to one of Parker's 12,000 worldwide distributor locations.

HoseFinder is currently available for iPhone®, Blackberry® and Android™ mobile phones... and at no charge.

Technical Handbook

Low-Pressure Push-Lok

The intelligent Push-Lok System covering different types of rubber, thermoplastic as well as a hybrid hose version and a wide selection of reusable fittings made from steel, brass and stainless steel.

Pressure range: Up to 2.4 MPa

Low-Pressure (Transportation, Air Conditioning, Others)

This low pressure range follows the No-Skive concept and can be assembled on Parkrimp machines.

Pressure range: Up to 20.7 MPa

Medium-Pressure Hydraulics

Hose and fitting product range for applications in mobile and industrial hydraulics. The perfect range for the more demanding market requirements with a broad selection of Parkrimp No-Skive fittings, with over sixty end configurations, combined with Parker hoses and crimpers allows simple and safe assembly – whenever and wherever needed.

Pressure range: Up to 42.5 MPa

High-Pressure Hydraulics

Heavy-duty products for heavy-duty applications with a full range of Parkrimp No-Skive multispiral hoses and fittings and of ParLock skive type hoses and fittings

Pressure range: Up to 56.0 MPa

Assembly Machines / Accessory Products

The perfect complement to the largest range of hoses and fittings in the market. Parker crimping technology is recognised throughout the industry as the easiest and most accurate crimping system available.

Whatever application you have

we have the best solution

Hose Products Division Europe supplies premier customer service by focussing on customer needs and analysing the entire business environment in which our customers operate.

Macro-market analysis is an important aspect of business planning to engineer and produce the best solution for our customers' requirements and help them to achieve higher levels of profitability.

- What are customers' needs and desires
- What hose technology do customers prefer
- How to advance customers' brand loyalty



Off Highway Mobile Equipment

Agricultural Equipment, Construction Equipment, Material Handling, Oilfield Equipment, Forest Equipment



Industrial Equipment

Robots, Machine Tools, Injection Moulding, Metal Processing, Air & Gas Compressors, Other Industrial Equipment



Transportation

Trucks, Buses, Railways, Military Vehicles



Processing Industry

Industrial Chemicals Processing, Oil & Gas Processing, Paper Mills



Marine

Ship Building, On-Shore, Off-Shore



Power Generation

Wind Power, Power Generation Equipment



Mining

Underground and Surface Mining, Hard Rock Drilling, Tunneling

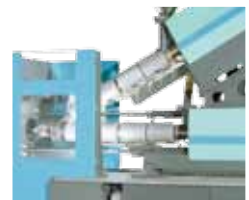



aerospace
climate control
electromechanical
filtration
fluid & gas handling
hydraulics
pneumatics
process control
sealing & shielding



Hydraulic Hoses, Fittings and Equipment

Technical Handbook



ENGINEERING YOUR SUCCESS.

Parkrimp *No-Skive* and ParLock System

Along with the ever-growing power and efficiency of construction, agriculture and other machinery and increasing working pressures and flow

rates of their hydraulic systems, multispiral hose is gaining an increasingly important role in machine design. Parker Hannifin, as the world

leader in the hydraulic hose market, responds to these highly demanding requirements with 2 comprehensive systems – Parkrimp No-Skive and ParLock.

Parkrimp *No-Skive* system

is based on no-skiving technology (without removing the rubber cover before assembling)

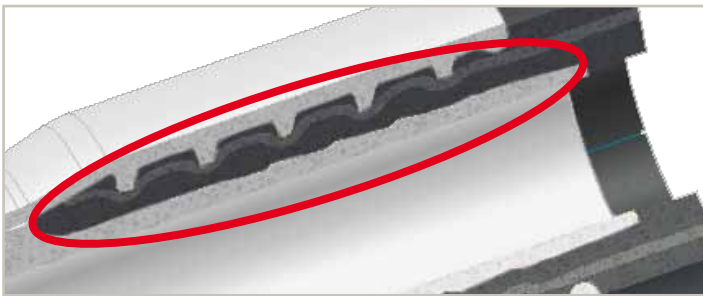

ParLock system

uses external or internal and external skiving (Interlock) technology

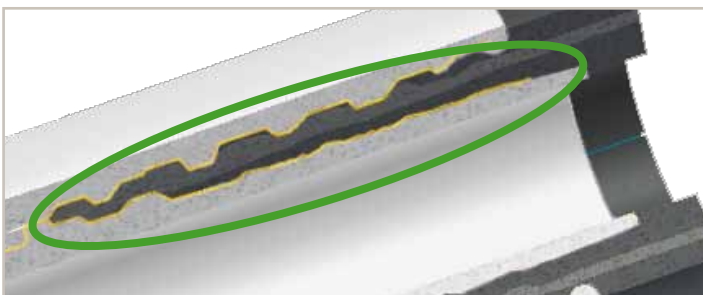

Each of the two concepts has its indisputable advantages – which concept should be selected depends on the particular conditions of the application.

Each of the Parkrimp No-Skive and ParLock systems consists of integrated ranges of hose, fittings and assembling equipment and know-how, all of which are:

- Designed and developed together
- Tested and approved together
- Produced and supplied together

This way Parker Hannifin can guarantee:

- The highest quality and safety and the longest service life of the final product – to the end users, and at the same time:
- The easiest, most efficient and safe production process – to the assemblers.

In this way Parker Hannifin also meets the requirements of SAE J1273 and ISO 17165-2, which pay particular attention to matching the hose with the fittings and to their compatibility proven by the manufacturer.

Parkrimp *No-Skive*

The easy to operate crimp system
from textile to 6 spiral high tensile steel wire

Parkrimp No-Skive is synonymous with the best solution for assembling hydraulic and related hose and fittings from both the technical and the manufacturing points of view!

Throughout the progressive rubber and metal compression during the crimping process the reinforcement always remains intact. The meticulous design,

testing and manufacturing processes of Parkrimp No-Skive hose and fittings, combined with the approved crimping diameters provide an excellent mechanical connection between the hose and the fitting. This absolutely leak-free connection gives long service life even with the highest pressures associated with 4- and 6-spiral hose assemblies.

The smartly designed and time-tested Parkrimp No-Skive assembling equipment combined with Parker's assembling know how allow the safest, most efficient and mistake-proof assembly process. The Parkrimp equipment allows cost and time savings to the assembler and guarantees a defect-free, reliable and durable final product to the end-user.

Parkrimp *No-Skive* hose and fittings

the system for fast and leak-free assemblies

- For crimping Parkrimp No-Skive fittings only
- No skiving tool needed
- No need to remove the cover
- Quick and easy: no gauges to set on the machine
- Portable machines for field repair
- Meets EN safety regulations

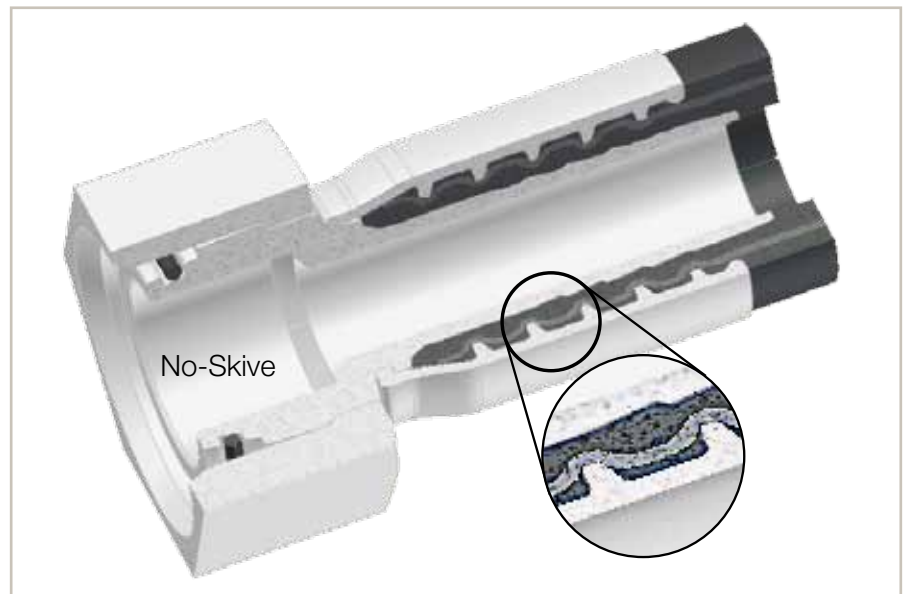

Parkrimp *No-Skive* hose and fittings the system with the perfect match

<p>The perfect match The complete system from one source. No-Skive hose, No-Skive fitting and crimping machine with world-wide guarantee and availability.</p>	<p>Parker's colour-coded die sets No loose parts to mismatch or misplace – die set segments linked together. Die sets provide 360° evenly applied crimping forces for an ideal crimp result.</p>	<p>Parkalign® Parker's exclusive Parkalign® positions the fitting in the dies perfectly every time.</p>



ParLock

The system for extremely dynamic pressure applications

Applications requiring the ParLock system

- Hydrostatic transmissions (combine harvesters, large tractors, excavators, etc.)
- Large injection moulding machines
- Tunnelling machines
- Forestry machines
- Large material handling machines (container handling)
- Excavator booms
- Blow-out preventers in oil and gas

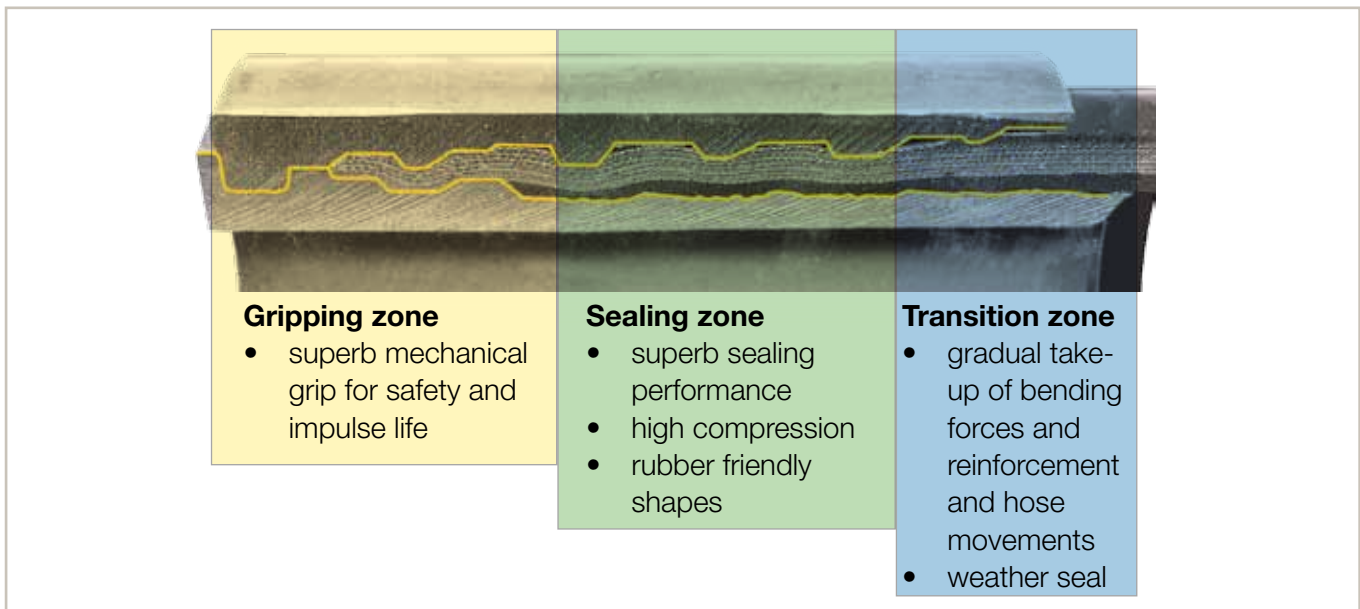

For manufacturing the ParLock hose assemblies Parker Hannifin offers

- Skiving machines for external and internal skiving
- Universal crimping machines with adjustable crimping diameter
- Detailed assembling instructions (see further in this catalogue)

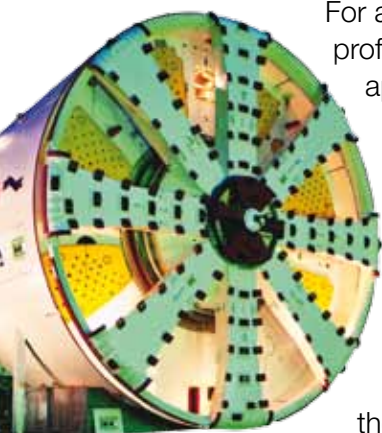

For applications with extremely dynamic pressure profiles, pressure surges and peaks, as well as applications with intense vibrations and hose flexing (bending), especially when close to the fitting, a strong mechanical grip by the fitting onto the hose is paramount.

A popular method accepted by the market of achieving this mechanical grip in such applications is to use hose fittings that „lock“ the metal reinforcement of the hose directly between the metal shell and nipple – for which the rubber of the hose has to be removed both

externally and up to a certain length also internally (a concept generally called „Interlock“).

As a response to the market requirement for an „Interlock“ hose fitting system, Parker has developed the Parlock program. This range consists of a specific range of hose, fittings and assembly equipment combined with Parker crimping know-how.

Hydraulic Hoses and Fittings

Hoses and Fittings Terminology – The basics	Aa-2 – Aa-8
Safe Hose Assemblies in 8 Steps	Aa-9
1 Application	Aa-9
2 Pressure	Aa-10
3 Size	Aa-10
4 Temperature	Aa-11
5 Fluid Compatibility	Aa11
6 Hose Fittings	Aa-11
7a Working Steps for One-Piece Parkrimp No-Skive Fittings	Aa-12 – Aa-14
7b Working Steps for Two-Piece ParLock Fittings	Aa-15 – Aa-16
8 Routing, Installation, Environmental influences	Aa-17 – Aa-19
How to Order (Part number description)	Aa-20 – Aa-21
Hoses and Fittings Storage	Aa-22 – Aa-23
Safety Precaution	Aa-24 – Aa-25
Proactive Maintenance Programme	Aa-26
Technical Data	
Hose Overview	Ab-2 – Ab-3
Hose Fittings Overview	Ab-4 – Ab-7
Hose Fittings Pressure Ratings	Ab-8 – Ab-10
Hose Fittings Nomenclature	Ab-11 – Ab-14
Classification Bodies	Ab-15
Classification Body Type Approvals	Ab-16 – Ab-17
Conversion Chart	Ab-18
Temperature / Pressure Chart	Ab-19
Flow Capacity Nomogram	Ab-20
The Correct Method to Fit Female Swivel Ends	Ab-21
Chemical Resistance Table	Ab-22 – Ab-30
Identifying Fitting Types	Ab-31 – Ab-41
Safety Guide	Ab-42 – Ab-45



Hoses and Fittings Terminology

– The basics!

Hydraulic hose is a full-value part of the hydraulic system transmitting the hydraulic power – not just conveying a fluid – and deserves adequate attention, just like the other hydraulic components which generate, consume or control that power. Furthermore, it is just hydraulic hose assemblies that are usually most exposed to various extreme conditions in which they have to retain full functionality and assure serviceability of the hydraulic system and safety of the operators.

In spite of that, the importance of the hydraulic hose is often overlooked and underestimated.

This catalogue is to provide guidelines to correct hoses and fittings selection and hose assembly manufacturing and to highlight the most important safety aspects for its service in the field.

Hydraulic Rubber Hoses

Tube – inner layer of rubber compound with chemical and physical properties to be long-term resistant to the fluid and working conditions.

Reinforcement – 1 or 2 (exceptionally 3) layers of braided textile fibre or highly tensile steel wire or 4 or 6 layers of spiralled very highly tensile steel wire to bear high pressure but allow flexibility of the hose.

Cover – outer layer of rubber compound with chemical and physical properties to protect the reinforcement against ambient conditions and mechanical damage.

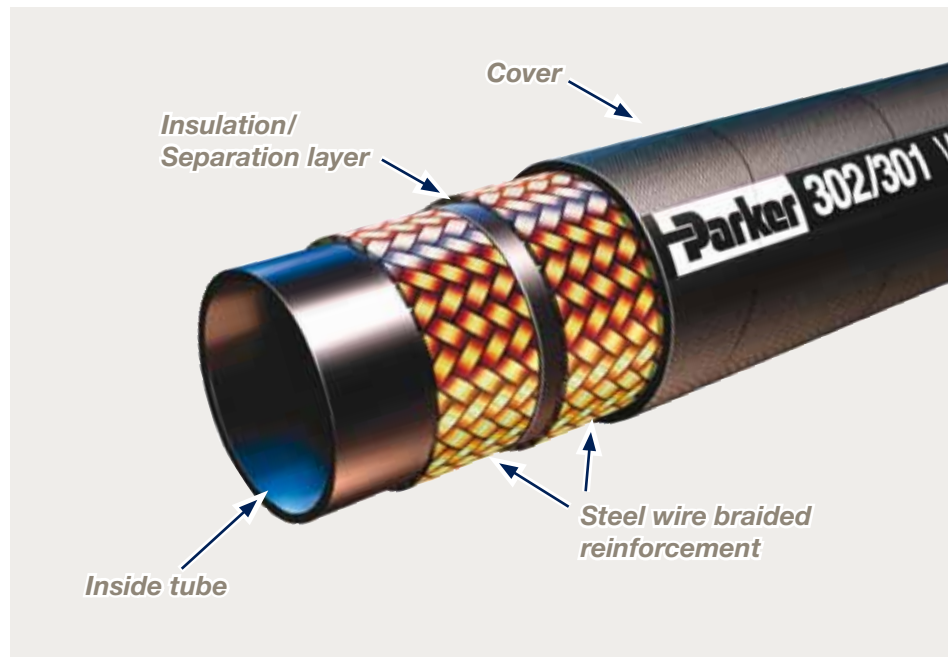

Depending on the pressure level we classify the hydraulic hoses in this catalogue into 4 groups:

- **Push-Lok**
 - low-pressure hoses with self-grip connection to fittings
- **Low pressure and Transportation**
 - 1 and 2 textile yarn braided and 1 steel wire braided hoses
- **Medium pressure**
 - 1 and 2 steel wire braided hoses and suction hoses
- **High pressure**
 - 3 steel wire braided hoses and 4 or 6 spiral steel wire braided hoses
 - 4 spiral steel wire braided compact hoses

Depending on the method of hose and fittings assembling we offer 2 basic product concepts (integrated product lines of hoses, fittings, assembling equipment and know-how):

- **Parkrimp *No-Skive***
 - complete range of braided and spiralled hose, not needing removing (skiving) of the hose cover before assembling.
- **ParLock**
 - specific range of 4 and 6 spiral hose for extreme applications which require skiving of the cover and for bigger sizes also of the inner tube.

Hose Fittings

Nipple (insert etc.) – the inner part of the fitting of which, one end is coupled to the counterpart of a hydraulic component (termination end), while the other end is inserted into the hose (tail end).

To assure compatibility and leak-free sealing of the hose fitting with the other connectors, designs of termination ends are standardized according to numerous national and international standards.

The main role of the tail end is to provide durable sealing between fitting and hose.



Shell (socket, ferrule etc.) – the outer part of the fitting provides mechanical connection of the fitting with the hose. To assure a strong hold of the hose reinforcement, shells are generally crimped on to the hose during assembly.

The design of the tail end and the shell profile is the sole responsibility of the respective manufacturer. Due to this reason many different designs are found in the market (only the design of the termination end and the functionality of the entire hose assembly is specified in the international standards).

Note

Parker Hannifin also offers a limited range of 2-piece Parkrimp No-Skive fittings but being special products they are not included in this catalogue. For more information about 2-piece fittings, please contact our Division Helpdesk (HPDE_Helpdesk@parker.com)

In this catalogue we offer 3 kinds of fittings:

- **Push-Lok**

- special nipples connectable to Push-Lok hose without any shells.

- **1-piece fittings**

- pre-crimped shells on nipples make the assembling of hose with fittings easier, more effective and reliable.

- **2-piece fittings**

- for extreme applications requiring full metal-to-metal connection of the hose reinforcement with the shell or even with the nipple (external or external plus internal skiving).

Except Push-Lok, all fittings in this catalogue are crimped and include:

- All Parker 1-piece fittings
 - suitable for the **Parkrimp No-Skive** product line
- All 2-piece fittings in this catalogue
 - suitable for the **ParLock** product line



Aa-4



Hose Assembly

It is the interplay between the fitting tail and shell designs and the hose design with its material properties that primarily determine performance, service, durability and safety of the final hose assembly. Yet compatibility of hose and fitting cannot be just theoretically projected. It requires exhaustive and repetitive laboratory and field tests and further tuning of the designs.

Non-compatibility of hose with fittings or even the combination of hose and fittings from different manufacturers, do not just only influence the performance of the hose assembly, they often lead to hose failure with serious health or life-threatening consequences! For this reason the main international standards ISO 17165-2 and SAE J1273 strictly warn not to mix hose with fittings from different manufacturers without their approval.

Parker Hannifin has not approved products of any other manufacturer for combination with Parker hoses and/or Parker fittings and guarantees full compatibility, reliability and safety only for combinations of genuine Parker parts selected and assembled in accordance with the guidelines included in this catalogue!

Hose Hint

Never mix & match one manufacturer's fittings with hoses from another manufacturer.

Parker hoses, fittings, assembling equipment and know-how are designed as an integrated system. Only this ensures optimum product performance, reliability and safety!



Pressure Rating

Hydraulic hose is a component transmitting hydraulic power and the pressure is obviously the main physical quantity determining the hydraulic power. For hydraulic hoses the following pressure ratings are used:

Working Pressure – the pressure for which the hose assembly is designed to operate over its whole service life - provided the other parameters (temperature in particular) stay within reasonable limits.

For apparently static applications (e.g. with hand pumps or water jetting) consult the Working Pressure with your Parker Field Representative or with our Technical Support (HPDE_Helpdesk@parker.com).



Burst Pressure – the pressure which statically applied causes destruction of the hose. Technical standards for hydraulic hoses define the burst pressure to be equal to or higher than **4 times the working pressure** (safety factor 4). This rule and the burst pressure in general serve to hose manufacturers for design and testing of the hose only! If you happen to know the burst pressure of certain hose, never use this rule backwards to deduce its working pressure!

$$4 \times \text{Working Pressure} = \text{Burst Pressure}$$



Hose and Fittings Terminology

Remember the working pressure

1. The **hose assembly working pressure** is given by the weakest "link in the chain" - i.e. by the lowest of the working pressures of the hose and of both fittings. Do not forget to check the working pressure of the fittings when selecting components for a hose assembly (see pages **Ab-8** to **Ab-10** of this catalogue)!
2. The **real hydraulic system operating pressure** is not given by the system components setup but by the application which introduces into the system peaks and surges or by the functioning of the system itself (rapid closing or opening) which induces spikes and pulses. Such occurrences are detectable only by sensitive electronic pressure gauges and are usually not fully or not at all filtered out by safety or relief valves and exert excessive strain on the hydraulic system – hoses and tubes first of all!
3. The **hose assembly working pressure** must always be **equal to or higher than the real hydraulic system operating pressure** incl. all peaks, surges, spikes and pulses!



Unit of measure

The most commonly used unit of measure for hydraulic pressure worldwide is MPa (Mega Pascal) – used also in this catalogue. In the US and in Anglo-Saxon markets also psi (pounds per square inch) is officially used and many European producers, users and even technical standards still also use bar.

For the conversion chart of various units of measure see page **Ab-18**.

Hose Hint

Working pressure is a dynamic parameter, burst pressure is a static parameter. High burst pressure does not mean high working pressure!

In order to assure mutual compatibility, producers of hydraulic equipment, producers of machines and also international technical standards profess certain preferred pressure levels:

MPa	21	28	35	42
bar	210	280	350	420
psi	3000	4000	5000	6000

4 x



=



Hose Hint

For highly demanding applications (dynamic pressure, high number of pressure cycles, high temperature etc.):

- Select hose with much higher working pressure than officially requested
- Select multispiral hose instead of braided or ParLock instead of Parkrimp No-Skive
- Select all of that in order to increase service life and safety!

Hose Size

The other parameter determining the hydraulic power in direct proportion is the flow rate – i.e. the fluid velocity. However, too high fluid velocity gives rise to turbulence, pressure drops and heating up of the fluid, causing excessive ageing of hoses and other components or even their damage. To keep the fluid velocity below certain limits but achieve the required flow rate, the size of the hose has to be defined appropriately (see Flow Capacity Chart on page **Ab-20**).

As the first technical standards for hose came from the USA, dimensions of hose are defined in inches and hose sizes are expressed in inches or from inch-derived units. Global companies – such as Parker – use **dash sizes** (-1 = 1/16”), while the European standards use DIN-based DN (diameter nominal) sizes.



dash	inch	DN	mm
-3	3/16	05	4.8
-4	1/4	06	6.4
-5	5/16	08	7.9
-6	3/8	10	9.5
-8	1/2	12	12.7
-10	5/8	16	15.9
-12	3/4	19	19.1
-16	1	25	25.4
-20	1.1/4	31	31.8
-24	1.1/2	38	38.1
-32	2	51	50.8

Note

SAE 100 R5 hydraulic hose, SAE J1402 air-brake hose and SAE J2064 air-conditioning hose use sizes equivalent to corresponding metal tube I.D. – different from the other hydraulic hoses (see datasheets of these hoses in this catalogue).

Size	Inch	mm	DN
-6	6/16	$6/16 * 25,4 = 9,525$	10
↓	↓	↓	↓
-6	3/8	9,5	10

Ambient and Fluid Temperature

Temperature is one of the factors which most negatively affect rubber characteristics and so it deserves particular attention of the hydraulic system designers and hose users!

High temperature causes degradation of rubber and accelerated ageing of the hose – an effect which can be yet further intensified by the chemical impact of the fluid. That is why the upper temperature limits specified in this catalogue refer to the fluid temperature and why they differ for various media. However, permanent or long-term use at temperatures close to the upper limit would considerably shorten the hose service life in any case and if it cannot be avoided the hose should be replaced more frequently once it shows first symptoms of deterioration (stiffness, hard cover and cracks).

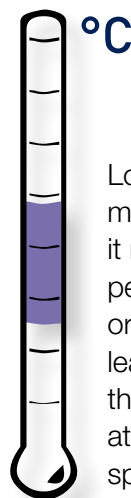

Aa-7

Hose Hint

The combination of high temperature and high pressure reduces the hose service life. Pay attention to regular inspection of such hoses and their preventive replacement if the cover is brittle or cracked!

Low temperature, on the other hand, affects mainly physical properties of rubber – making it more fragile – and so at extremely low temperatures hose being bent may crack in tube or cover which can cause immediate or later leakage, burst or reinforcement damage. As there are not many hydraulic fluids which flow at or below -40 °C, the lower temperature limits specified in this catalogue refer rather to ambient temperature below which the hose should not be bent or otherwise hit from outside (while staying passively in it does not cause serious problems).

Hose Bend Radius

Hose Hint

Bend radius and bending force are two different things! Not even apparently “flexible” hose (with low bending force) may be bent below the min. allowed radius!

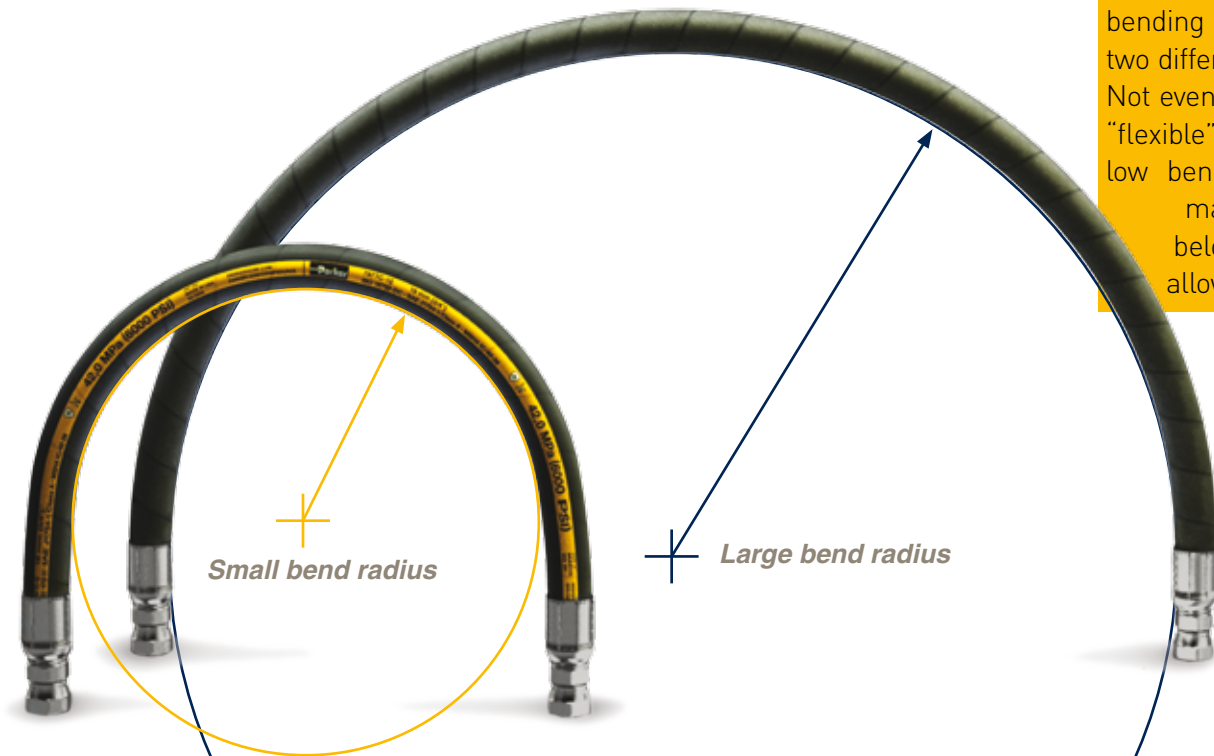

Remember

In order not to displace the hose reinforcement and/or damage its tube or cover, hydraulic hoses must never be bent below the min. bend radius specified in this catalogue – even without any pressure or even in bulk when stored or packed!

The role of hydraulic hose is to provide a connection of relatively movable parts of the circuit and so its bending is a natural state the hose is designed for. However, the layout of the reinforcement wire or fibre inside a bent hose **may** shift to less appropriate positions. The tube and cover are stretched and become thin-

ner and so the pressure resistance of a bent hose considerably decreases. For this reason working pressure and bend radius are negatively interdependent parameters and the max. working pressures specified in this catalogue are conditioned by respecting the min. bend radii.

Recommended Fluids

As the power transmitting – not fluid conveying – element, hydraulic hose should be first of all used for the primary applications and with the recommended fluids specified in this catalogue!

For low pressure applications with various non-hydraulic fluids see our catalogue “**4401 Industrial Hoses**”.

If for required higher pressure or for any other reason you cannot use industrial hoses, follow the instructions in this catalogue (pages **Aa-9** – Application, **Aa-11** – Fluid Compatibility and **Ab-22** to **Ab-30** – Chemical Resistance Table).

Safe Hose Assembly in 8 Steps

1. Application

There are so many operational factors affecting the functionality and service life of hydraulic rubber hoses and there is such a wide variety of external circumstances they have to work in that some few basic parameters such as pressure, size and fitting types cannot provide a sufficient basis for selecting and producing the proper product.

The only unfailing way is to start ... from the end – to learn and thoroughly understand the application the hose assembly will work in.

Hose Hint

You do not always need additional sleeve to protect the hose against abrasion!

Parker high and extremely high abrasion resistant **TOUGH COVER** and **SUPER TOUGH** versions with 80-times and 450-times higher abrasion resistance do the same, but better and cheaper!

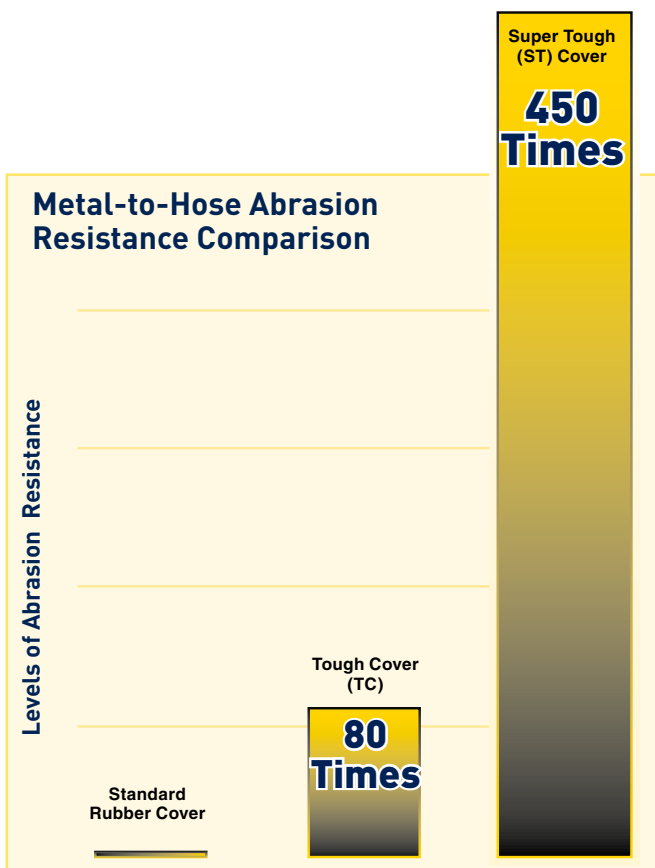

Main operational factors:

- Market (agriculture, construction, marine, mining, ...)
- Machine / equipment type
- Hydraulic system pressure
- Static / dynamic
- Extreme pulses (frequency, amplitude)
- Surges, peaks, spikes
- Suction strains
- Flow rate
- Ambient / fluid temperature (permanent, peak)
- Biodegradable oil
- Other fluid – liquid / gaseous
- Bend radius
- etc.

Main external circumstances:

- Extreme environmental conditions
- Ultraviolet light / sunlight
- Ozone / smog / salt water
- Restricted space
- Abrasives / sharp-edged objects
- Mechanical loads (strain, stress, torsion)
- Mechanical vibrations
- Fittings heated
- Fittings under voltage / current
- Electrical / magnetic field
- Heat exposure
- Flame / fire exposure
- etc.

Other requirements:

- Certificate / approval needed
- Special (OEM) specification
- Environmental requirements
- Work safety requirements

Safe Hose Assembly in 8 Steps

2. Pressure

Working pressures of both hose and fittings must be equal to or higher than the real hydraulic system operating pressure incl. all surges, peaks, spikes and pulses!



For hose working pressure rates see pages **Ab-2** to **Ab-3** Hose Overview.

For fittings working pressure rates see pages **Ab-8** to **Ab-10** Hose Fittings Pressure Ratings.

For the absolute majority of hydraulic applications incl. for the highest pressure 4- and 6-spiral hoses we advise to use the **Parkrimp No-Skive** product line. It provides really supreme solutions for hydraulic and related hoses and fittings from both the technical and the manufacturing points of view!

For applications with extremely pulsing dynamic pressure, pressure surges and peaks, as well as for applications with intense mechanical vibrations and hose flexing (bending), especially close to the fittings, we recommend using the **ParLock** product line.

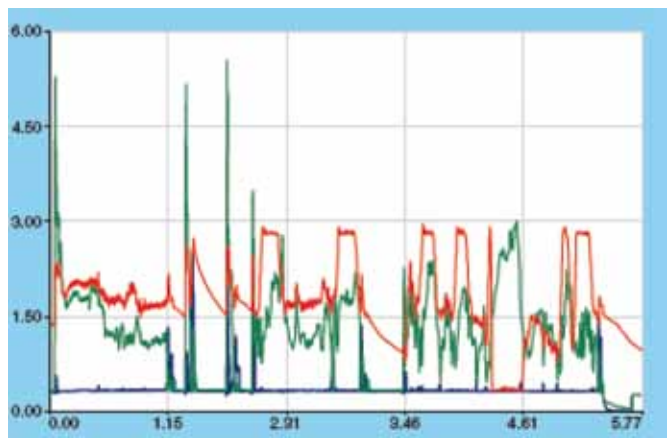

3. Size

To avoid turbulence and their negative consequences for hose and other components in the hydraulic circuit, certain limits for fluid velocity have been set based on long-term experience with hydraulic systems. The limits differ for pressure, return and suction lines, as the hydraulic flow tends to turbulences the more the lower the pressure.

Max. recommended fluid velocity:

- Pressure lines – ca. 6.1 m/sec
- Return lines – ca. 3 m/sec
- Suction lines – ca. 1.2 m/sec

However, there is no need to calculate the velocity. Depending on the flow rate and kind of hydraulic line in which the hose is intended to serve (pressure / return / suction) you can assign the required hose size in the Flow Capacity Nomogram on page **Ab-20**.



Hose Hint

Don't try to save your own or your customer's money by downsizing the hose!

It would cost your customer more to replace damaged hoses, other components and oil, and it will cost you more as you may lose your customer!

The size of the hose is directly included in the hose part number: e.g. 302-6-ISO 1436/DIN EN 8532SN hose size -6 (3/8"- DN10)



High Temperature

For high temperature hoses choose the part numbers ending in “6”

– e.g. **436-12** - SAE 100R16

High Temperature hose size -12

Low Temperature

For extremely low temperature hoses choose the part numbers ending in “LT” –

e.g. **461LT-16** – DIN EN 857-2SC

Low Temperature Hose size -16

4. Temperature

The main technical standards for hydraulic hoses specify the max - min temperature range usually (not always) as:

- EN standards and EN/DIN-based ISO standards
-40 °C to +100 °C
- SAE standards and SAE-based ISO standards
-40 °F to +250 °F / -40 °C to +121 °C

For Parker hoses you can find the recommended temperature ranges for fluids and for water and air (when applicable) in the datasheet of each hose type in this catalogue.

Besides a complete range of standard hoses Parker also offers a wide range of special types for low and high temperatures – see pages **Ab-2** to **Ab-3** Hose Overview.

5. Fluid Compatibility

You can find recommended fluids for Parker hoses in the datasheet of each hose type in this catalogue.

If the required fluid is not mentioned in the Recommended Fluids Chart and if due to higher pressure or for any other reason you cannot use Parker industrial hoses (see Parker catalogue “4401 Industrial Hoses”) pay the highest attention to obtain as much information as possible about the fluid (temperature, pressure, state – liquid or gaseous etc.) and about the working conditions of the hose (see par. 1. Application).

Then check the compatibility of the fluid with the given hose and material of the fitting in the Chemical Resistance Table pages **Ab-22** to **Ab-30**.

The Chemical Resistance Table concerns solely the hose inner tube. Hydraulic hoses should never be submerged in the hydraulic fluids! If you need to know the resistance of the hose cover, consult our Technical Support (HPDE_Helpdesk@parker.com)

6. Fittings

Hose Hint

Although fittings are made of steel, their working pressure is often lower than that of hose! Don't forget to check the working pressures of both fittings when selecting components for your hose assembly!

Even if the fitting termination end is given by the other component in the hydraulic circuit or the hose assembly is just for replacement, you have to pay attention to choosing the correct fittings compatible with the given hose for the required working pressure and fluid.

To identify the corresponding termination end see pages **Ab-31** to **Ab-41** Identifying Fitting Types.

For each type of hose the series of the compatible fitting is indicated in the hose datasheets in this catalogue – e.g. Parker hose 701 is to be assembled only with Parker Fittings Series 70.

Always check the fitting working pressure – see pages **Ab-8** to **Ab-10** Hose Fittings Pressure Ratings.



7a. Working Steps for 1-Piece Parkrimp *No-Skive* Fittings

Cutting

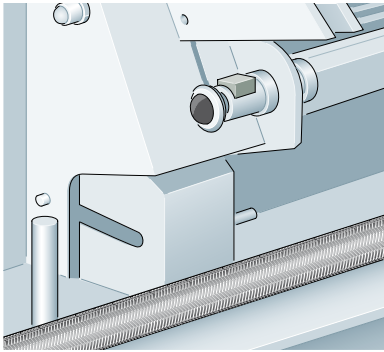

Hose is cut to the desired length according to specifications. The correct hose cutting tool ensures a square, clean cut without damaging the pressure reinforcement. Depending on the hose type, different kinds of cutting blades must be used:

- 1) Smooth cutting blade:
for high tensile textile layer, return line hoses and steel wire braided hoses
- 2) Serrated cutting blade:
for hoses with 4 or 6 spiral layer of high tensile steel wire

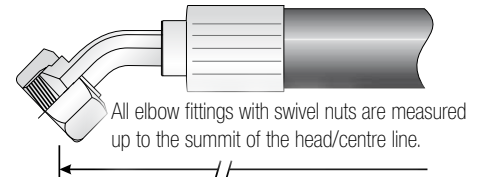
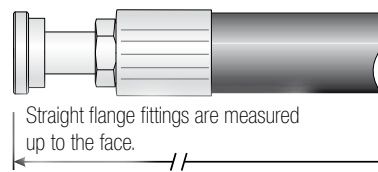
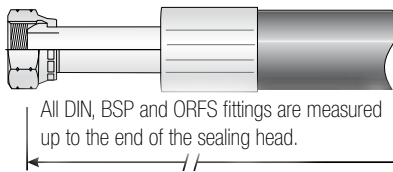
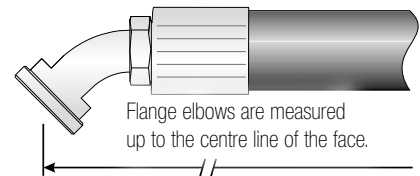
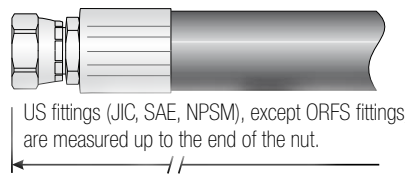
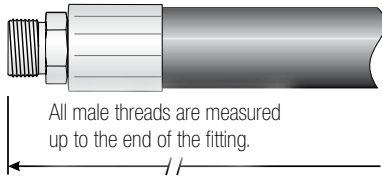

Tolerances for hose assemblies

Length tolerance according to DIN 20066 and DIN EN 853 to DIN EN 857

Hose assembly length	up to DN25 (size -16)	from DN32 (size -20) up to DN50 (size -32)	from DN60 (size -40)
up to 630	+7 -3	+12 -4	+25 -6
over 630 up to 1250	+12 -4	+20 -6	
over 1250 up to 2500	+20 -6	+25 -6	+25 -6
over 2500 up to 8000		+1,5 % -0,5 %	
over 8000		+3 % -1 %	

According to DIN EN ISO 4413, hose assemblies are not permitted to be manufactured from any components that have already been in use in other hose assemblies.

Cleaning after cutting

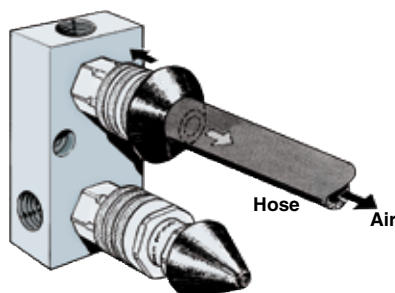

After cutting it is recommended to clean the hose with compressed air from both sides. Please make use of Parker's Cleaning System TH6-7 – A quick and simple system – Delivered with two plastic nozzles for hoses from size -4 up to -32. The hose is pressed against the nozzle and thereby opens a valve to allow the compressed air to blow through the hose and blow out loose particles.

Marking

According to EN and ISO standards, hose assemblies must be clearly and permanently marked. They must bear the following information:

- Manufacturer's identification
- Date of production (year and month)
- Maximum permissible working pressure limit of hose assembly

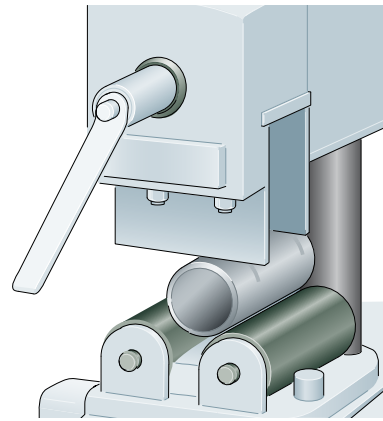

Crimping 1-Piece Parkrimp No-Skive Fittings

Crimping is the safest, fastest and most commonly used method of making a hose assembly. The Parker crimping systems ensure precise, leak-free and tear-proof assembly of hose and fitting. Reaching the exact crimping diameter is possible with Parkrimp crimping tools or adjustable crimping tools. When crimping, it is essential that hose, fitting and crimping tool (dies) match precisely. For crimping dimensions please refer our crimp charts on pages **Ed-1** to **Ed-11**.

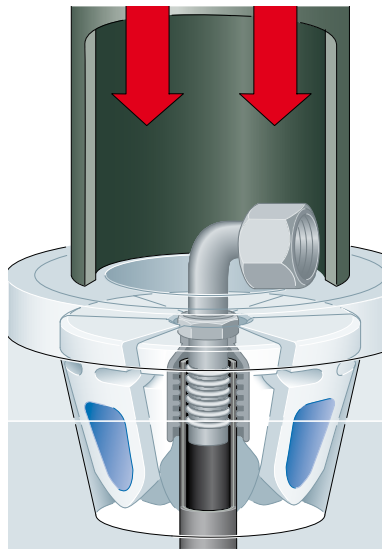

Furthermore, the insertion depth, a square cut hose, correct, burr-free and clean crimping are important to ensure a correctly formed and leak-free connection of hose and fitting. Using the Parkrimp hose crimpers or adjustable crimpers, the fitting is crimped onto the hose in one slow and smooth crimping procedure. A depth stop with automatic function ensures safe positioning of the fitting. This guarantees the correct crimping of hydraulic hose assemblies.

26, 46, 48, 70, 71, 73, 76, 77, 78, 79, S6 series:

Push the hose all the way into the coupling.

Place the hose next to the fitting shell and mark the insertion depth or the length of the fitting onto the hose – (lubricate hose end if necessary), push the hose into the fitting until the mark on the hose is even with the end of the shell.

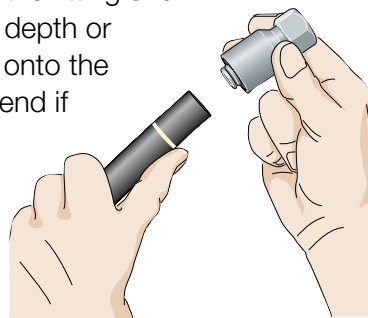

Angle setting

The displacement angle of a hose assembly is indicated only when two elbow fittings are assembled in a displaced way.

The angle always has to be indicated clockwise looking from the elbow fitting at the back to the one in the front. Please also consider the natural bending of the hose.

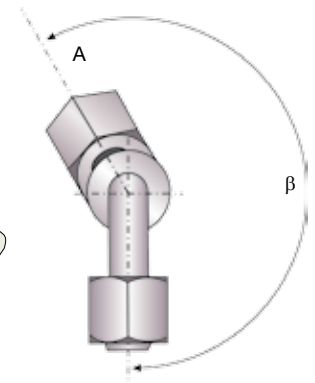

**Parker representatives
can support you with
training or advice !**

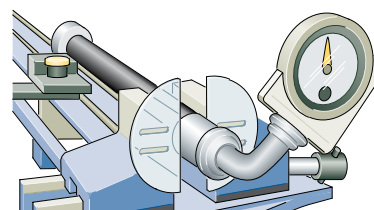

Safe Hose Assembly in 8 Steps

Testing (optional)

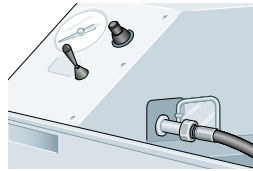

Static test pressure depending on the hose type and application is applied to the finished hose assembly for a pre-defined period of time. The test procedure can be documented using a test logging unit. The test pressure for Parker hydraulic hose assemblies is 2 times the value of the dynamic operating overpressure.

Proof Pressure Test

This test is typically carried out on customer request according to a method defined by the ISO 1402 standard. The test should be done at normal ambient temperature with a proof test bench using water or another suitable liquid. The hose assembly should be pressurised for between 30 to 60 seconds at twice the working pressure of the hose assembly. There should be no leakage or pressure drop. A complete test report should be provided together with the hose assembly to the customer.

Cleaning

The hydraulic systems have to reach a defined degree of cleanliness. For this purpose we use cleaning devices which ensure fast and efficient cleaning of hose assemblies.

With the TH6-6 standard cleaning device, certain cleanliness classes can be achieved. This cleaning device first flushes the hose assembly with an anticorrosive emulsion and dries it afterwards with pressurised air.

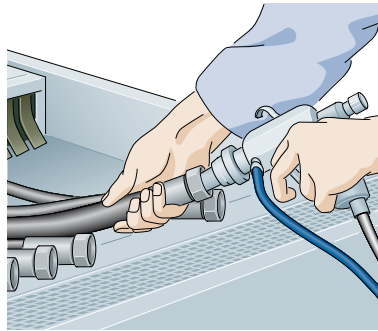

For permanent protection of the finished hose assembly against impurities we recommend using plastic caps.

ISO 4406	NAS 1638	SAE 749
11/8	2	
12/9	3	0
13/10	4	1
14/11	5	2
15/12	6	3
16/13	7	4
17/14	8	5
18/15	9	6
19/16	10	
20/17	11	
21/18	12	



7b. Working Steps for 2-Piece ParLock Fittings

Cutting, cleaning after cutting and marking please see “Working Steps for 1-Piece Parkrimp No-Skive”

Skiving

For the skiving of hydraulic hose, one distinguishes between internal skiving and external skiving. This system is applied for hose types with 4 or 6 spiral reinforcement layers, the so-called Parker ParLock System or Interlock.

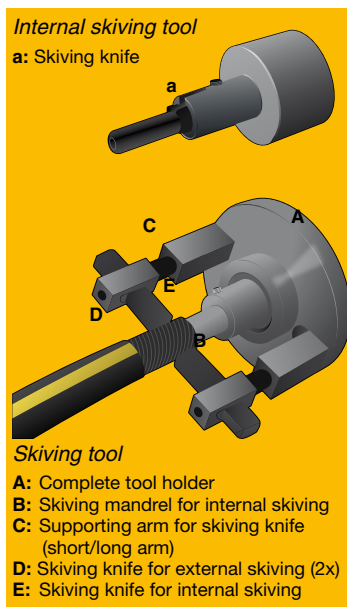

Adjustment of tools for internal skiving

Select the skiving tool according to the manufacturing documents and the hose size. Insert the knife for the internal skiving mandrel into the borehole of the mandrel provided for this purpose and mark it with a lock collar at the straight surface. When adjusting the knife, observe the marking on the internal skiving knife and insert the mandrel into the tool holder.

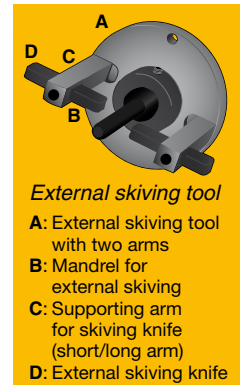
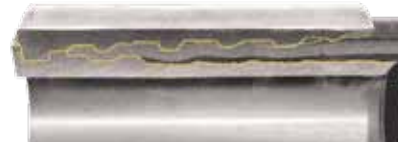

Adjustment of tools for external skiving

Attach the knives in the supporting arm. Select the supporting arm (long or short) depending on the hose size. Adjust the knives according to the Parker working instructions and insert the tools into the machine. Push the mandrel onto the hose until it is close to the tool (external or internal skiving knife).

Adjustment of the sense of rotation of the machine

Always skive into the direction of the spiral layers. Please observe the operation instructions of the machine.

Cleaning after skiving

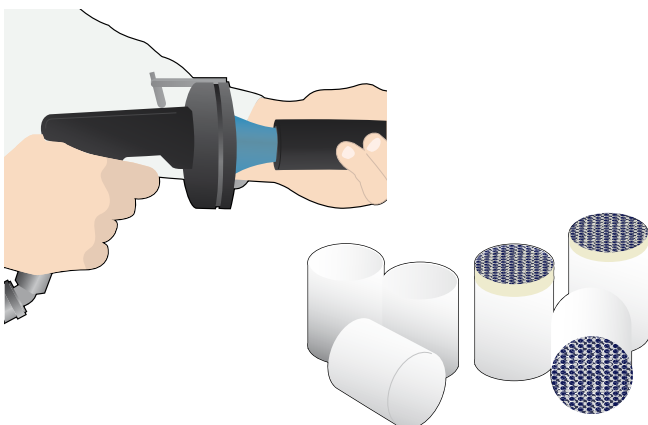

All hose types which have been skived externally or internally should be cleaned immediately after skiving. For this purpose we recommend using cleaning plugs which are shot through the hose using compressed air. (e.g. TH6-10-EL-7 or TH6-10-HL-9-2)

In addition to this working step, the finished hose assembly must be cleaned from both ends using pressurised air after the completion of this working step.

Safe Hose Assembly in 8 Steps

Crimping 2-Piece ParLock Fittings



For crimping ParLock fittings V4 series a minimum of 320 tons crimping force is recommended. Min. of 340 tons for V6 series.

- 1) Select the appropriate crimping dies using the crimping diameter chart.
- 2) Before crimping hoses and fittings it must be ensured that you have the most recent crimping dimensions. For crimping dimensions please refer our crimp charts on page **Ed-12** to **Ed-13**.
- 3) Insert the dies into the crimping press and set the crimping diameter.
- 4) Place the pre-assembled hose assembly into the crimper and perform the crimping procedure.
- 5) Please observe the operating instructions of the crimper.

! 2-piece fittings must not be crimped on Parkrimp crimpers – only with adjustable crimpers.



Make sure that the hose ends are cut squarely. Push the ferrule onto the hose. The cut end of the hose must be clearly visible.

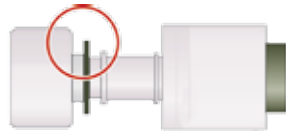

Push the nipple down into the hose until it reaches the stop on the lower groove (plastic ring, fitting shoulder or metal stop). Use Hoze-Oil, if required.



The ferrule must bottom up against the plastic ring or metal stop.

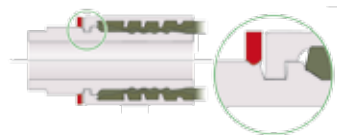

After crimping, the ferrule must be located precisely in the groove of the nipple.

Angle setting

please see “Working Steps for 1-Piece Parkrimp No-Skive”

Checking for the correct crimping diameter

In case of the ParLock System, the conicity is measured. It is measured at the beginning and the end of the ferrule in 2 measuring planes.

The conicity must be within the tolerance range specified in the Parker specification.



Measurement 1 in the plane of force



Measurement 2 displaced by 90°



Measurement 1 at the beginning and the end of the ferrule



Measurement 2 at the beginning and the end of the ferrule (displaced by 90°)

Testing and cleaning please see “Working Steps for 1-Piece Parkrimp No-Skive Fittings”

8 Routing / Installation / Environmental Influences

wrong

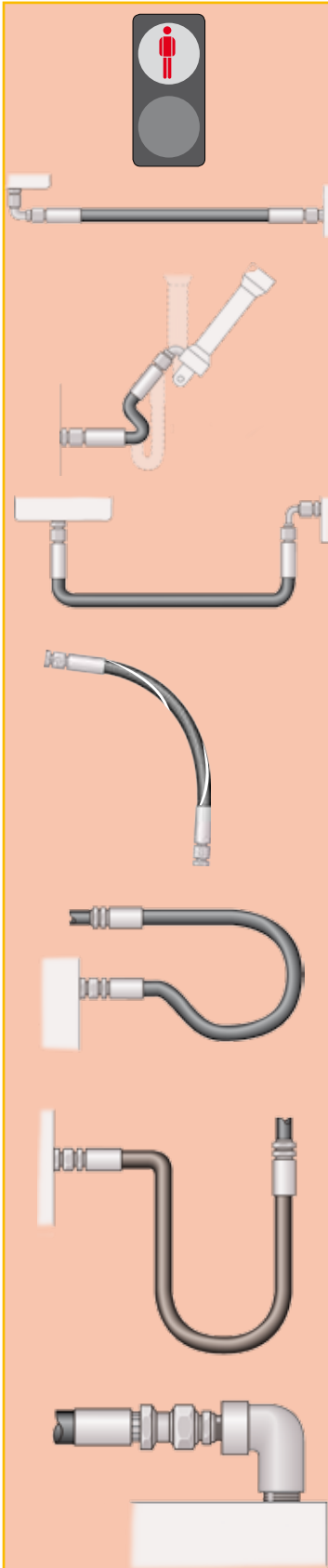

The **routing** of the hose assembly and the environment in which the hose assembly operates directly influence the service life of the hose assembly. The following diagrams indicate the correct routing of hose assemblies that will maximise its service life and assure a safe working functionality.

When hose installation is straight, it must be assured that there is enough slack in the hose to allow for changes in length that occur when pressure is applied. When pressurized, hose that is too short may pull loose from its hose fittings or stress the hose fitting connections, causing premature metallic or seal failures.

The **hose length** must be determined so that the hose assembly has enough slack to allow the system components to move or vibrate without creating tension in the hose.

However, care needs to be taken not to allow too much slack and therefore introduce the risk of the hose snagging on other equipment or rubbing on other components.

Mechanical straining of the hoses needs to be avoided, so the hose must not be bent below its minimum bend radius or twisted during installation. The minimum bending radii for each hose is stated in the hose tables in the catalogue.

The plane of movement must also be considered and the hose routing selected accordingly.

Hose routing also plays an important role on the selection of the hose fittings, as the correct fittings can avoid straining the hoses, unnecessary hose length or multiple threaded joints.

right

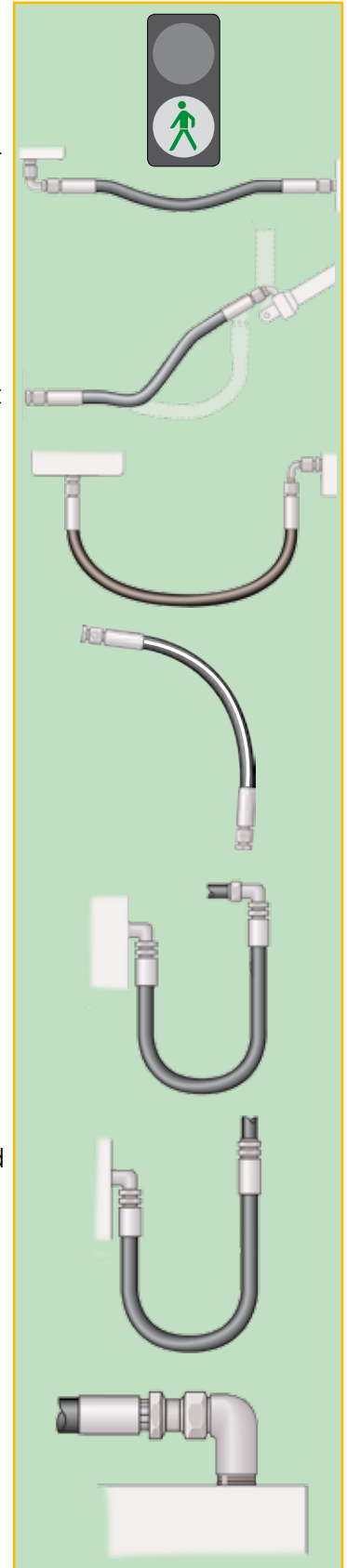

Safe Hose Assembly in 8 Steps

wrong

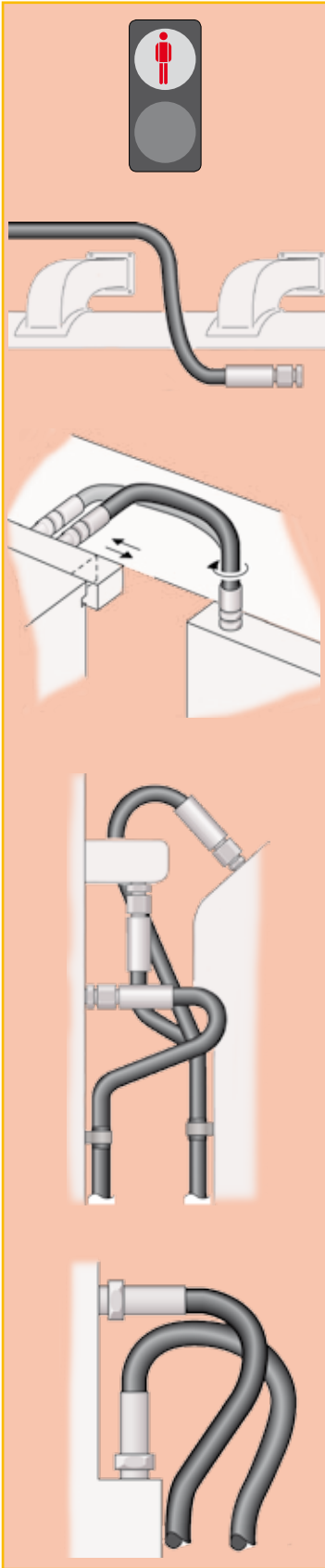

Correct clamping (holding/supporting) of the hose should be exercised to securely route the hose or to avoid the hose contacting surfaces that will cause the hose damage.

It is however, vital that the hose be allowed to keep its functionality as a “flexible-pipe” and not be restricted from changing in length when under pressure.

It should also be noted that hoses for high- and low-pressure lines shall not be crossed or clamped together, as the difference in changes in length could wear the hose covers.

Hose should not be bent in more than one plane. If hose follows a compound bend, it shall be coupled into separate segments or clamped into segments that each flex in only one plane.

Hoses should be kept away from hot parts as high ambient temperatures shorten hose life. Protective insulation may need to be used in unusually high ambient temperature areas.

Whilst the importance of the functionality is prime the aesthetics and practicality of the installation should also be considered in the design.

It should be considered that maintenance might be necessary at some stage in the future, so prohibitive design routings should be avoided.

right

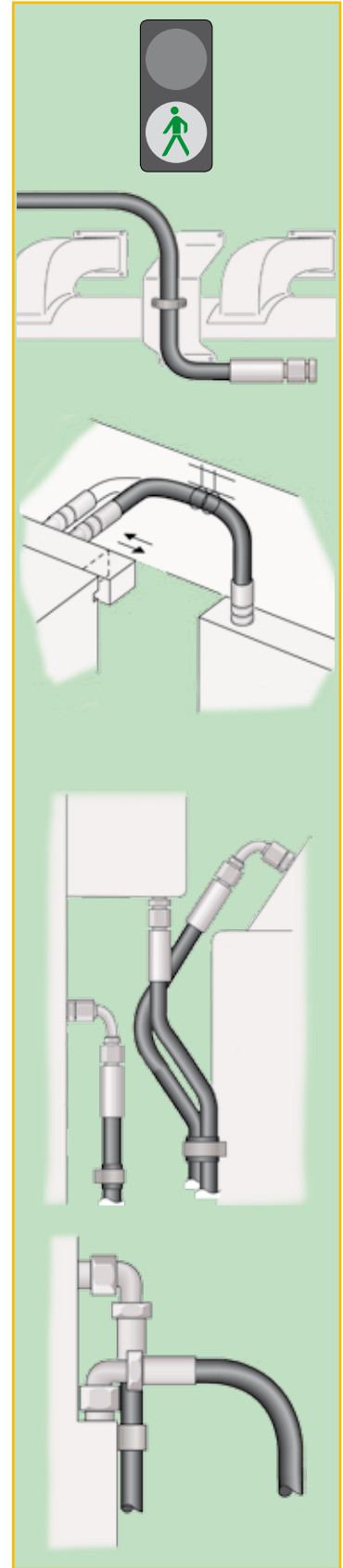

wrong

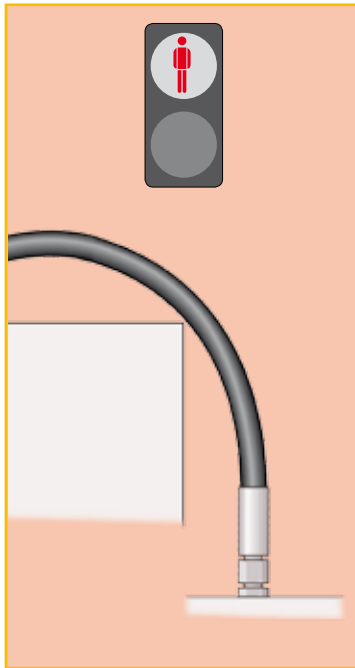

Abrasive influences

In general care should be taken that the hose is not exposed to direct surface contact that will cause abrasive wearing of the outer cover (either hose to object or hose to hose contact). If however, the application is such that this cannot be avoided, either a hose with a higher abrasion resistant hose cover or a protective sleeve need to be used.

Parker **TOUGH COVER** (TC) or **SUPER TOUGH** (ST) covers offer 80 times or respectively 450 times the abrasion resistance of standard rubber covers.

right

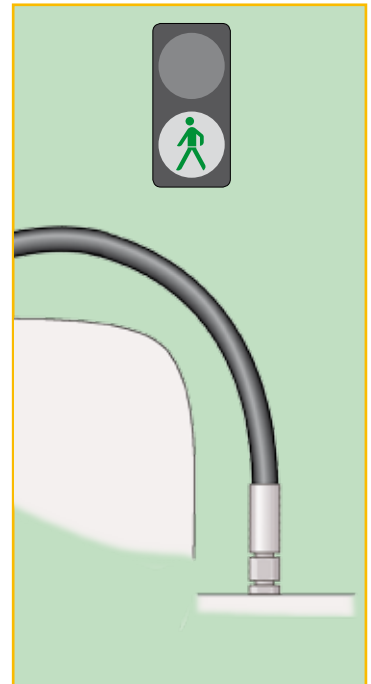

Pollution of hydraulic circuits

Modern hydraulic equipment is becoming highly precise and as such more sensitive, so as a result the importance of a clean working fluid in the system is growing. Because as many as 75 % of hydraulic system failures are caused by contamination of the fluid by solid particles, the initial cleanliness of hydraulic components, as the main source of these contaminants, is vital. With hose assemblies most of the pollution/contaminates enter the hose assembly during its production and mainly during the cutting (or skiving) process.

In order to avoid system failures, all hose assemblies should be cleaned before use (cleaned and plugged before shipping) with suitable cleaning equipment such as the Parker TH6-6 machine.

The level of contamination is defined in three popular norms: ISO4406, ISO4405 or NAS 1638. Most common however, is the ISO 4406, which describes the number and size of solid particles in the hydraulic system by means of a classification value e.g. 16/13.



ISO 4406	NAS 1638	SAE 749
11/8	2	
12/9	3	0
13/10	4	1
14/11	5	2
15/12	6	3
16/13	7	4
17/14	8	5
18/15	9	6
19/16	10	
20/17	11	
21/18	12	

How to Order

To make ordering Parker products easier, we have itemized the order numbers on this page. This will be especially helpful when you order hose assemblies. You can find further useful hints on the following page.

1. Hose

Example: **436-6**



436-6 > **Hose type**

436-6 > Hose **inside diameter** in size

2. Hose Fittings

Example: **1 CA 48 - 12 - 6**

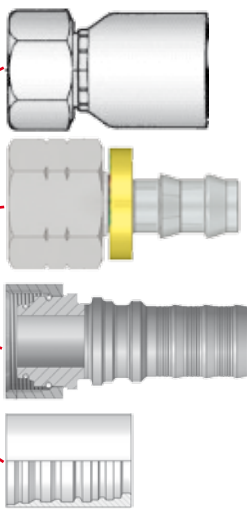

1 = Crimp fitting

3 = PushLok fitting

K = Nipple component (ParLock fittings)
example: KC9VS-16-8

100 = Shell component (ParLock fittings)
example: 100VS-8

1 CA 48 - 12 - 6 > **Fitting**

1 **CA** 48 - 12 - 6 > **End configuration nomenclature**

1 CA **48** - 12 - 6 > **Parker Fitting series**

1 CA 48 - **12** - 6 > **Thread or tube size**

1 CA 48 - 12 - **6** > **Hose size and hose fitting size**

I.D. = size -6

Material/ specification:

- Without suffix: steel, zinc plated
- B: brass
- C: stainless steel
- K: without a plastic ring
- SM: metric hexagon dimension

The content of the hose crimping tables shows the standard part numbers. For the availability of non standard parts/materials please contact your local Parker service centre. All part numbers printed in bold in the respective price list are available ex-stock.

3. Hose Assemblies

Example: **P436CACF12106-1000-0-SG900**

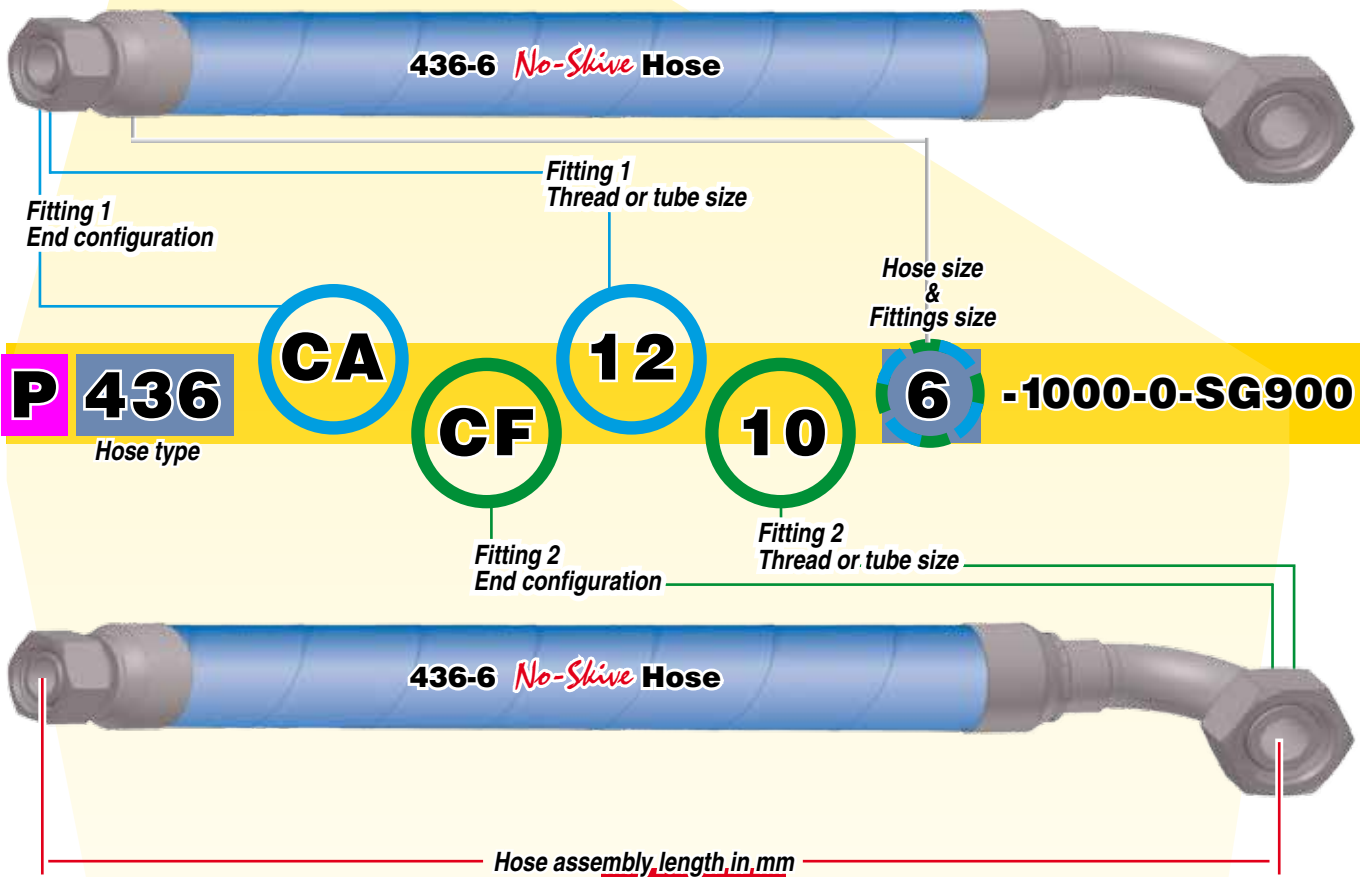

P **436** **CA** **CF** **12** **10** **6** **-1000-0-SG900**
 Hose type Fitting 1 End configuration Fitting 1 Thread or tube size Hose size & Fittings size Fitting 2 End configuration Fitting 2 Thread or tube size

P436CACF12106-1000-0-SG900

- R = Low Pressure Push-Lok Fittings Series 82
- P = Parkrimp *No-Skive* Fittings Series 26, 48
- D = Parkrimp *No-Skive* Fittings Series 46
- F = Parkrimp *No-Skive* Fittings Series 70, 71, 73, 76, 77, 78, 79 and S6
- E = Parlock Skive Fittings Series VS
- V = Parlock Skive Fittings Series V4
- S = Parlock Skive Fittings Series V6

Accessory,
e.g. spring guard 900 mm length

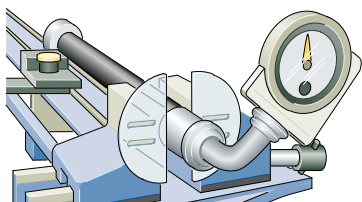

Displacement angle is relevant when the hose assembly has bent fittings

SG	Spring Guard
AG	Armour Guard
AS/PS	Partek Nylon protective sleeve
FS	Fire Sleeves
HG	PolyGuard-Hose Protector
PG	ParKoil-Hose Protector

Explanation of the example

Hose assembly with hose 436 in size -6 and fitting series 48. Hose assembly length 1000 mm.
 Fitting 1: end configuration CA has a 12 mm pipe diameter and has a size -6 hose nipple
 Fitting 2: end configuration CF has a 10 mm pipe diameter and has a size -6 hose nipple
 The displacement angle for this combination is 0 degrees. On request a displacement angle can be specified for the bent fitting in relation with the hose curvature. A protection sleeve as a spring guard in length 900 mm is on the hose assembly.

Hose and Fittings Storage

It is a well-known fact that rubber properties deteriorate during the time of storage and service. A system of hose age control should be maintained to ensure that hose is used as long as it retains full capabilities for rendering the intended service. However, it is impossible to advise the ideal storage period and service life of rubber hose as it is subject

to a variety of factors which may affect the rubber characteristics and the suitability for use. That is also why various standardization committees take very different approaches to rubber hose storage period and service life. The main national and international standards defining rules for rubber hose storage are the following:

DIN 20066

Fluid power systems – Hose assemblies – Dimensions, requirements

Specifies bulk hose shelf life and hose assembly storage period and service life:

- The shelf life of bulk hose before assembling must not exceed 4 years.
- The service life of a hose assembly, incl. any period of storage, must not exceed 6 years.
- The period of storage of a hose assembly must not exceed 2 years.

Bulk Hose

Hose Assembly

Shelf life – max. 4 years	Service life – max. 6 years Storage max. 2 years
------------------------------	--

BS 5244

Recommendations for application, storage and life expiry of hydraulic rubber hoses and hose assemblies

Specifies tests needed for various storage periods of hose (in bulk or hose assembly):

- Storage period does not exceed 3 years – no tests needed.
- Storage period is between 3 and 5 years – proof pressure test needed.
- Storage period is between 5 and 8 years – proof pressure, burst, impulse, cold flexibility and electrical tests needed.
- Bulk hose or a hose assembly older than 8 years – must be scrapped.

For hose assembly service life no explicit limits are specified, whereas it is recommended to establish rules for each particular equipment and application on the basis of records taken from the real service.

ISO 17165-2 / SAE J1273

Hydraulic fluid power – Hose assemblies – Recommended practices for hydraulic hose assemblies

The specified max. shelf life of bulk hose or a hose assembly is 10 years (40 quarters) from the date of manufacture (vulcanization) of the hose, provided it has been stored in accordance with ISO 2230 (Rubber products - Guidelines for storage) and passes visual inspection and if need be also a proof pressure test. If visual inspection gives rise to any doubts as to the functionality of the hose (cracks in the cover or tube after hose flexing, excessive stiffness, reinforcement rust etc.), a proof pressure test should be carried out before use or the hose should be scrapped.

Hint

German and the British standards are the most rigorous.

ISO 8331

Rubber and plastic hoses and hose assemblies – Guide to selection, storage, use and maintenance

Specifies storage periods similar to DIN 20066 – bulk hose max. 4 years, a hose assembly max. 2 years. If the storage exceeds these limits the hose must be inspected and tested (tests are not specified). Hose assembly service life is not specified.

OEM regulations

In addition to these national and international standards, also some Original Equipment Manufacturers (OEMs) have their own regulations for age of hose used for production of hose assemblies.

We recommend generally observe the regulations relevant for your country or ISO 17165-2 (if there is no domestic regulation), plus the regulation of your customer's country or of your OEM customer in the extent in which they are more demanding.

Hoses storage

– best practices

Store hoses and hose assemblies in a cool, dark and dry room with capped ends in closed boxes (preferably in the original Parker packaging) and in the manner facilitating inspection of the hose condition and the first-in first-out (FIFO) inventory control system.

The main factors determining the hose storage are:

a) Temperature

Preferably between 15 °C and 25 °C, without rapid and frequent fluctuation.

b) Humidity

Preferably not higher than 65 %, protect hose against moisture and avoid atmospheric humidity condensation.

c) Heat

Store hose away from heat sources.

d) Light

Protect hose against direct sun light, light of discharge lamps and other ultraviolet sources.

e) Corrosive liquids and fumes

Do not store in the same room with corrosive chemicals.

f) Ozone

Avoid using high power electrical equipment and electrical spark sources in the storage room.

g) Oils and greases

Avoid direct contact.

h) Space and bends

Keep hose in stress-free shape never bent below the min. bend radius.

i) Electrical and magnetic fields

Store hose away from powerful electric transformers, motors and generators that could induce current in the hose metal reinforcement.

j) Rodents and insects

Protect against rodents and insects.

Fittings storage

– best practices

For storing fittings the same rules as for hose are applicable (especially for fittings with rubber sealing), in addition:

a) Mismatching and confusing

Avoid unnecessary repacking and store fittings in clearly marked closed containers (preferably in the original Parker packaging).

b) Damage of threads and sealing surfaces

Avoid unnecessary reloading and handling.

c) Fittings with O-rings

Assure that storage period of fittings with O-rings or other rubber sealing does not exceed 2 years (remember: first in-first out).

d) Caps

Hose assemblies fittings should be capped against damage and contamination.



Safety First!

A hydraulic hose assembly is a power component and may cause property damage, personal injury or death!

WARNING: Injuries in which hydraulic or other liquid is involved must be treated without delay and not the same way as an ordinary injury!

1. High pressure fluid injection can be almost invisible, leaking from a pinhole, but it can pierce the skin deep into the muscle!
2. If a fluid-injection accident occurs, search immediately for a medical treatment by a doctor!
3. Don't touch pressurized hydraulic hose assemblies and don't look at them from a short distance – especially not close to fittings!
4. Secure ends of hydraulic assemblies with high pulsing pressure and all high pressure air hose assemblies against blow-off of the hose from the fitting with appropriate whip restraints!
5. Stay out of hazardous areas while testing hose assemblies under pressure and wear proper protective clothing and goggles!

We in Parker are making all efforts to develop, manufacture and deliver defect-free, durable and safe products and services – starting from integrated design and testing of all components through sharing our know-how with our customers and providing them with comprehensive support and training.

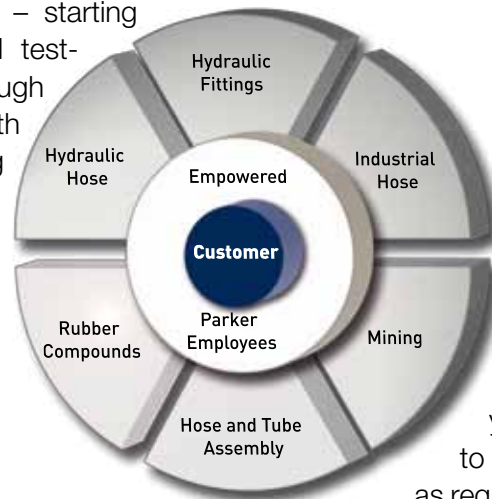

Please also make all efforts on your side to provide reliable and safe hose assemblies to your customers and forward to them the know-how you acquired, whether from us or due to your own unique experience, especially as regards the proper use and maintenance of hose assemblies.

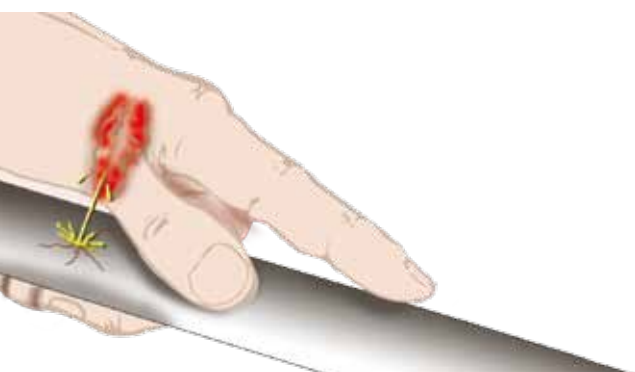

Avoid injury to yourself and others by following these important rules



Carefully read and observe especially the following sections of this catalogue

- For selection of proper hose and fittings:
 - Safe Hose Assembly in 8 Steps (pages **Aa-9** ff)
 - Technical Data (pages **Aa-2** ff)
- For manufacturing of hose assemblies:
 - Working Steps for 1-Piece **Parkrimp** *No-Skive* Fittings (pages **Aa-12** ff)
 - Working Steps for 2-Piece **ParLock** Fittings (pages **Aa-15** ff)
- For storing, packing and handling:
 - Hose and Fittings Storage (pages **Aa-22** ff)
- For installation on machines:
 - Routing / Installation / Environmental Influences (pages **Aa-17** ff)
- For inspection, maintenance and replacement:
 - Preventive Maintenance Program (page **Aa-26**)
- **READ CAREFULLY AND OBSERVE:**
 - **Parker Safety Guide** for Selecting and Using Hose, Tubing, Fittings and Related Accessories (pages **Ab-42** ff)
- **INVESTIGATE, STUDY AND OBSERVE all relevant international and national standards and directives** of your local trade, technical and work safety associations, such as:
 - **ISO 17165-1** *Hydraulic Fluid Power – Hose Assemblies*
 - **ISO 17165-2** *Hydraulic Fluid Power – Hose Assemblies*
 - **ISO 4413** *Hydraulic fluid power – General rules and safety requirements for systems and their components*
 - **SAE J1273** *Recommended Practices for Hydraulic Hose Assemblies*
- In Germany**
 - **BGR 237** *Hydraulik-Schlauchleitungen – Regeln für den sicheren Einsatz*
 - **FA 015** *Hydraulik-Schlauchleitungen Prüfen und Auswechseln*
 - **BGI 5100** *Sicherheit bei der Hydraulik-Instandhaltung*
- In UK**
 - **BFPDA D8** *Quality Control Procedures and Requirements for BFPDA Distributors*
 - **BFPDA D14** *A Simple Rule for Re-ending Hydraulic Hose Assemblies – Don't*
 - **BFPDA P47** *Guidelines for the Use of Hydraulic Fluid Power Hose and Hose Assemblies*

Hose Hint

There are several analogies between hydraulic and electric systems and it is not inappropriate to compare high-pressure hydraulic hoses to high-voltage electrical cables and to advise to regard and handle them with similar caution and care!

Preventive Maintenance Programme

“All hoses will eventually fail, it’s just a matter of when” it is an often ignored but essential fact to remember when working with hydraulic hoses. Moreover, if a hose suddenly fails, it can have direct consequences, including increased labour and

material cost, unscheduled downtime and, most seriously, injury or even death of the personnel close the hose. **Avoiding failure should be a prime directive for any work processes which use hydraulic hoses.**

Be preventive, not reactive!

A preventive hose maintenance program, including even preventive replacement of not-yet-failed hose assemblies, is far more cost-effective than reacting to a hose assembly failure plus it provides a number of other advantages. It’s essential not to look just at the initial purchase price of a new hose assembly but to the total costs in consequence of a potential failure:

- Cost of lost fluid
- Pollution-related costs
- Costs of other more expensive components damaged due to hose failure
- Machine downtime
- “Costs” related to safety and health – hard to identify and not at all expressible in numbers!



The Preventive Maintenance Program includes a scheduled plan of visual inspections and preventive hose replacement, in case the hose assembly shows signs of an impending failure:

- Damaged, cracked, cut or abraded hose cover
- Exposed reinforcement
- Cracked, damaged or corroded fittings
- Leaks in fitting, perspiring hose cover close to fitting
- Kinked, crushed, flattened or twisted hose
- Hard, stiff, cracked or charred hose
- Blistered, soft, degraded or loose cover
- Fitting slippage on hose
- etc.

Hose Hint

A good analogy is automobile tyres. Just like hose, tyres are made of rubber, age with time and experience a lot of strain from the conditions they work in. Most drivers are cautious to replace tyres once they show signs of wear, not leaving it to destiny when they break on the road! So why don't they do it with hydraulic hoses?



As there are countless factors influencing the hose life, there cannot be and are not any exact guidelines to determine when a hose assembly has to be replaced or to judge how long it will work. Yet, we do have a tool to influence and determine the hose life:

Visual Inspections + Preventive Replacement = Preventive Maintenance Program!

Technical Data







Technical Data

Hose Overview	Ab-2 – Ab-3
Hose Fittings Overview	Ab-4 – Ab-7
Hose Fittings Pressure Ratings	Ab-8 – Ab-10
Hose Fittings Nomenclature	Ab-11 – Ab-14
Classification Bodies	Ab-15
Classification Body Type Approvals	Ab-16 – Ab-17
Conversion Chart	Ab-18
Temperature / Pressure Chart	Ab-19
Flow Capacity Nomogram	Ab-20
The Correct Method to Fit Female Swivel Ends	Ab-21
Chemical Resistance Table	Ab-22 – Ab-30
Identifying Fitting Types	Ab-31 – Ab-41
Safety Guide	Ab-42 – Ab-45

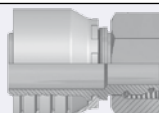

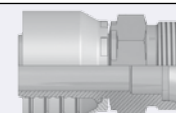
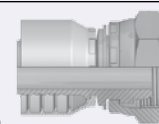
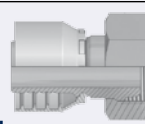
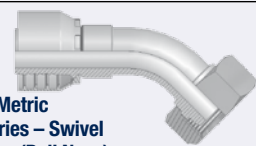
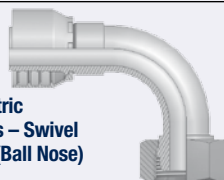
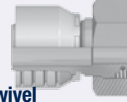

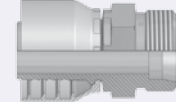
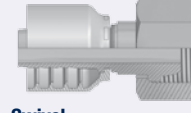
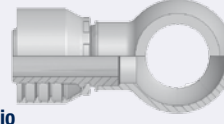
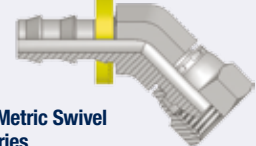

Hose	Working Pressure (MPa) in Size											Temp.	Construction	Standard	Page			
	-3	-4	-5	-6	-8	-10	-12	-16	-20	-24	-32					-40	-48	
Medium pressure																		
Railway	35.0	29.7	28.0	24.5	19.2	15.7	14.0										ISO 11237-R16 - SAE 100R16 DIN EN 853-1SN - ISO 1436-1SN/R1AT - SAE 100R1AT	Ca-16 Ca-8
Water cleaning		20.0	20.0	17.5													-	Ca-28 Ca-22
Pilot		10.0	10.0	10.0	10.0												-	Ca-6 Ca-7
Wire cover		19.0	15.5	13.8			8.6	6.9									ISO S1436-1SN/R1AT - SAE 100R1AT	Ca-10
Powerlift		45.0	42.5	40.0	38.0	35.0	25.0										Exceeds DIN EN 853-2SN - DIN EN 856-2SC Exceeds DIN EN 853-2SN - DIN EN 856-2SC	Ca-24 Ca-25
Extremely flexible		21.0	21.0	21.0	21.0	21.0											Exceeds SAE 100R17	Ca-29
Suction							2.1	1.7	1.4	1.0	0.7	0.4	0.4				Exceeds SAE 100R17 SAE 100R4 SAE 100R4	Ca-30 Ca-31 Ca-32
Standard				44.5	41.5	35.0	28.0										-	Da-2
Low temperature				44.5	41.5	35.0	28.0										-	Da-1
High abrasion res.				44.5	41.5	35.0	28.0										-	Da-4
Railway				44.5	41.5	35.0	28.0										-	Da-3
Standard				45.0	41.5	35.0	28.0			29.0	25.0						DIN EN 856-4SP - ISO 3862-4SP DIN EN 856-4SH - ISO 3862-4SH	Da-5 Da-7
Phosphate Ester				42.0	38.0	35.0	28.0			35.0	35.0						DIN EN 856-R13 - ISO 3862-R13 - SAE 100R13 DIN EN 856-R13 - ISO 3862-R13 - SAE 100R13	Da-11 Da-12
Extreme pressure				42.0	38.0	35.0	28.0			35.0	35.0						-	Da-10 Da-17
High abrasion resistance MSHA approved				56.0	56.0												ISO 3862-R15 - SAE 100R15	Da-8
Low temperature				28.0	28.0	28.0	21.0	17.5									DIN EN 856-R12 - ISO 3862-R12 - SAE 100R12 SAE 100R13 - ISO 3862 Type R13 - ISO 18752-DC SAE 100R15 - ISO 3862 Type R15 - ISO 18752-DC	Da-6 Da-13 Da-15 Da-15
Compact spiral !				35.0	35.0	35.0	35.0	42.0									-	Da-9 Da-14 Da-16
Standard		50.0		44.5	41.5	39.0	35.0	31.0									Exceeds DIN EN 856-4SP - ISO 3862-4SP Exceeds DIN EN 856-4SH - ISO 3862-4SH DIN EN 856-R13 - ISO 3862-R13 - SAE 100R13 ISO 3862-R15 - SAE 100R15	Da-22 Da-18 Da-25 Da-27
High abrasion resistance MSHA approved		50.0		44.5	41.5	39.0	35.0	31.0									Exceeds DIN EN 856-4SP - ISO 3862-4SP Exceeds DIN EN 856-4SH - ISO 3862-4SH DIN EN 856-R13 - ISO 3862-R13 - SAE 100R13 ISO 3862-R15 - SAE 100R15 Exceeds ISO 3862 Type R15	Da-23 Da-20 Da-26 Da-28 Da-30
Extreme abrasion resistance		50.0		44.5	41.5	39.0	35.0	31.0									Exceeds DIN EN 856-4SP - ISO 3862-4SP Exceeds DIN EN 856-4SH - ISO 3862-4SH ISO 3862-R15 - SAE 100R15	Da-24 Da-21 Da-29
Railway				40.0	40.0	40.0	40.0	40.0									Exceeds DIN EN 856-4SH - ISO 3862-4SH	Da-19



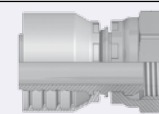

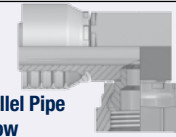
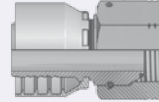

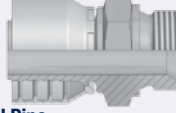
DIN – Metric

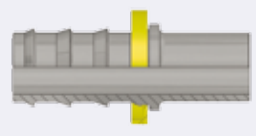
<p>CA</p>  <p>Female Metric 24° Light Series with O-Ring Swivel – Straight ISO 12151-2-SWS-L – DKOL</p>	<p>CE</p>  <p>Female Metric 24° Light Series with O-Ring Swivel – 45° Elbow ISO 12151-2-SWE 45°-L – DKOL 45°</p>	<p>CF</p>  <p>Female Metric 24° Light Series with O-Ring Swivel – 90° Elbow ISO 12151-2-SWE-L – DKOL 90°</p>	<p>D0</p>  <p>Male Metric 24° Light Series – Rigid Straight ISO 12151-2-S-L – CEL</p>
<p>C0</p>  <p>Female Metric Very Light Series LL Swivel – Straight (Ball Nose) DKM</p>	<p>C3</p>  <p>Female Metric Light Series – Swivel Straight (Ball Nose) DKL</p>	<p>C4</p>  <p>Female Metric Light Series – Swivel 45° Elbow (Ball Nose) DKL 45°</p>	<p>C5</p>  <p>Female Metric Light Series – Swivel 90° Elbow (Ball Nose) DKL 90°</p>
<p>C9</p>  <p>Female Metric 24° – Swivel Heavy Series with O-Ring Straight ISO 12151-2-SWS-S – DKOS</p>	<p>0C</p>  <p>Female Metric 24° – Swivel Heavy Series with O-Ring 45° Elbow ISO 12151-2 – SWE 45°-S – DKOS 45°</p>	<p>1C</p>  <p>Female Metric 24° – Swivel Heavy Series with O-Ring 90° Elbow ISO 12151-2-SWE-S – DKOS 90°</p>	<p>D2</p>  <p>Male Metric 24° – Rigid Heavy Series – Straight ISO 12151-2-S-S – CES</p>
<p>C6</p>  <p>Female Metric – Swivel Heavy Series – Straight (Ball Nose) DKS</p>	<p>49</p>  <p>Metric Banjo Straight DIN 7642</p>	<p>9B</p>  <p>Female Metric Swivel Light Series 45° Elbow</p>	<p>9C</p>  <p>Female Metric Swivel Light Series 90° Elbow</p>



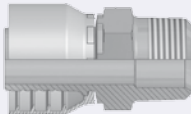

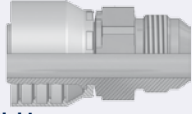
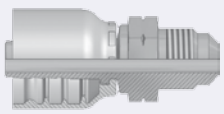
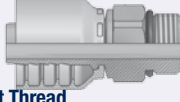
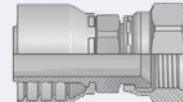
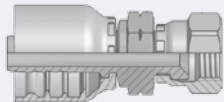
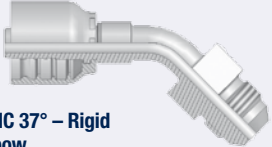
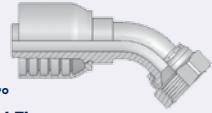
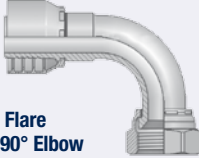





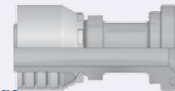

BSP

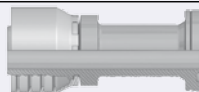
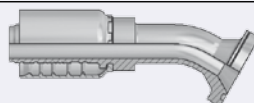
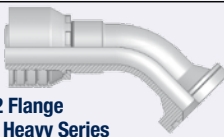
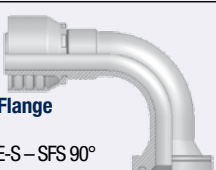
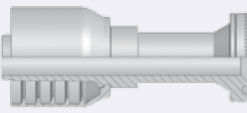
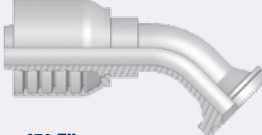
<p>92</p>  <p>Female BSP Parallel Pipe Swivel – Straight (60° Cone) BS5200-A – DKR</p>	<p>B1</p>  <p>Female BSP Parallel Pipe Swivel 45° Elbow (60° Cone) BS 5200-D – DKR 45°</p>	<p>B2</p>  <p>Female BSP Parallel Pipe Swivel 90° Elbow (60° Cone) BS 5200-B – DKR 90°</p>	<p>B4</p>  <p>Female BSP Parallel Pipe Swivel – 90° Elbow Block Type (60° Cone) BS 5200-E – DKR 90°</p>
<p>EA</p>  <p>BSP Swivel Female with O-Ring (60° Cone) BS 5200 – ISO 12151-6 – DKOR</p>	<p>EB</p>  <p>BSP Swivel Female with O-Ring 45° Elbow (60° Cone) BS 5200 – ISO 12151-6 – DKOR 45°</p>	<p>EC</p>  <p>BSP Swivel Female with O-Ring 90° Elbow (60° Cone) BS 5200 – ISO 12151-6 – DKOR 90°</p>	<p>D9</p>  <p>Male BSP Parallel Pipe Rigid – Straight (60° Cone) BS5200 – AGR</p>
<p>91</p>  <p>Male BSP Taper Pipe – Rigid Straight BS5200 – AGR-K</p>	<p>B5</p>  <p>Female BSP Parallel Pipe Swivel Straight (Flat Seat)</p>	<p>34</p>  <p>Inch Standpipe (Brass)</p>	



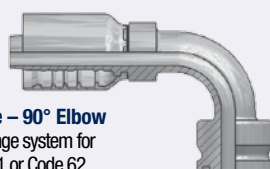
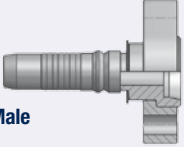
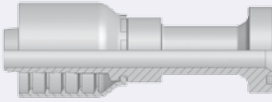

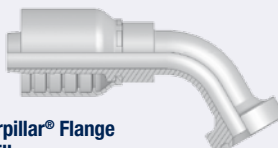
SAE

<p>01</p>  <p>Male NPTF Pipe Rigid – Straight SAE J476A / J516 – AGN</p>	<p>02</p>  <p>Female NPTF Pipe – Rigid Straight SAE J476A / J516</p>	<p>03</p>  <p>Male JIC 37° – Rigid Straight ISO12151-5-S – AGJ</p>	<p>04</p>  <p>Male SAE 45° – Rigid Straight SAE J516</p>
<p>05</p>  <p>Male SAE Straight Thread with O-Ring – Rigid Straight ISO 11926 – SAE J516</p>	<p>06/68</p>  <p>Female – JIC 37° SAE 45° Dual Flare Swivel – Straight ISO12151-5-SWS – DKJ</p>	<p>08</p>  <p>Female SAE 45° – Swivel Straight SAE J516</p>	<p>33</p>  <p>Male JIC 37° – Rigid 45° Elbow ISO 12151-5 – AGJ 45°</p>
<p>37/3V</p>  <p>Female JIC 37° SAE 45° – Dual Flare Swivel Female 45° Elbow ISO 12151-5-SWE 45° – DKJ 45°</p>	<p>39/3W</p>  <p>Female JIC 37° SAE 45° – Dual Flare Swivel Female 90° Elbow ISO 12151-5-SWES – DKJ 90°</p>	<p>41/3Y</p>  <p>Female JIC 37° / 45° Swivel Female 90° Elbow (Long) ISO 12151-5-SWEL – DKJ 90°L</p>	<p>L9</p>  <p>Female JIC 37° – Swivel 90° Elbow – Medium Drop ISO 12151-5-SWEM – DKJ 90° M</p>

Flange

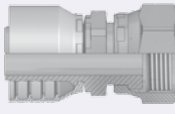
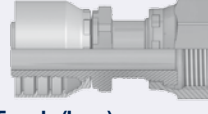
<p>15/4A</p>  <p>SAE Code 61 Flange Straight ISO 12151-3-S-L – SFL 5000 psi</p>	<p>16</p>  <p>SAE Code 61 – Flange Head 22.5° Elbow ISO 12151-3-E22ML – SFL 22.5° 3000 psi</p>	<p>17/4F</p>  <p>SAE Code 61 Flange 45° Elbow ISO 12151-3 – E45S – L – SFL 45° 5000 psi</p>	<p>19/4N</p>  <p>SAE Code 61 Flange 90° Elbow ISO 12151-3-E-L – SFL 90° 5000 psi</p>
<p>6A</p>  <p>SAE Code 62 Flange Straight ISO 12151-3-S-S – SFS 6000 psi</p>	<p>6E</p>  <p>SAE Code 62 Flange 30° Elbow SFS 30°</p>	<p>6F</p>  <p>SAE Code 62 Flange 45° Elbow – Heavy Series ISO 12151-3 – E45S – SFS 45° 6000 psi</p>	<p>6N</p>  <p>SAE Code 62 Flange 90° Elbow ISO 12151-3 – E-S – SFS 90° 6000 psi</p>
<p>8A</p>  <p>Flange – Straight 8000 psi</p>	<p>8F</p>  <p>Flange – 45° Elbow 8000 psi</p>	<p>8N</p>  <p>Flange – 90° Elbow 8000 psi</p>	<p>X5</p>  <p>Flange – Straight Full flange system for Code 61 or Code 62</p>
<p>X7</p>  <p>Flange – 45° Elbow Full flange system for Code 61 or Code 62</p>	<p>X9</p>  <p>Flange – 90° Elbow Full flange system for Code 61 or Code 62</p>	<p>PY</p>  <p>Flange – 24° Male French Gas Straight</p>	<p>XA</p>  <p>Caterpillar® Flange Straight</p>
<p>XF</p>  <p>Caterpillar® Flange 45° Elbow</p>	<p>XG</p>  <p>Caterpillar® Flange 60° Elbow</p>	<p>XN</p>  <p>Caterpillar® Flange 90° Elbow</p>	

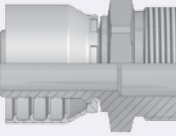
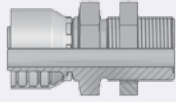

ORFS

<p>JC</p>  <p>Female ORFS Swivel – Straight Short ISO 12151-1 – SWSA SAE J516 – ORFS</p>	<p>JS</p>  <p>ORFS Swivel Female (Long) ISO 12151-1-SWSB SAE J516 – ORFS</p>	<p>J7</p>  <p>Female ORFS – Swivel 45° Elbow ISO 12151-1 – SWE 45° SAE J516 – ORFS 45°</p>	<p>J9</p>  <p>Female ORFS – Swivel 90° Elbow – Short Drop ISO 12151-1 – SWES SAE J516 – ORFS 90°</p>
<p>J1</p>  <p>Female ORFS – Swivel 90° Elbow – Long Drop ISO 12151-1 – SWEL SAE J516 – ORFS 90° L</p>	<p>J5</p>  <p>Female ORFS – Swivel 90° Elbow – Medium Drop ISO 12151-1 – SWEM – ORFS 90° M</p>	<p>JM</p>  <p>ORFS Male ISO 12151-1-S – SAE J516</p>	<p>JD</p>  <p>Male ORFS Bulkhead with Locknut Straight (with O-ring) ISO 12151-1 – SAE J516</p>

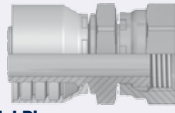
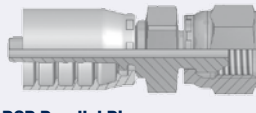
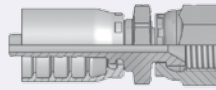
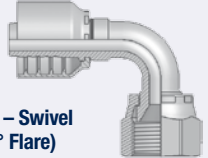
JIS

<p>FU</p>  <p>Female BSP Parallel Pipe Swivel – Straight (30° Flare) ISO 228-1 – JIS B8363 – GUI</p>	<p>GU</p>  <p>Female BSP Parallel Pipe Swivel – Straight (60° Cone) ISO 228-1 – JIS B8363 – GUO</p>	<p>MU</p>  <p>Female Metric – Swivel Straight (30° Flare) JIS B8363 – MU</p>	<p>MZ</p>  <p>Female Metric – Swivel 90° Elbow (30° Flare) JIS B8363</p>
--	---	---	---

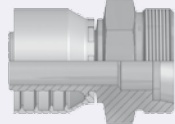

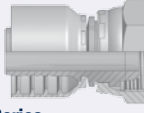
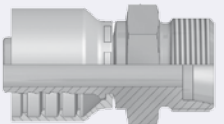
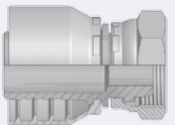
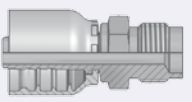



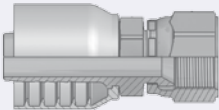
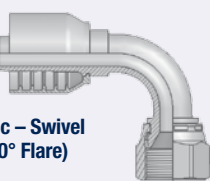
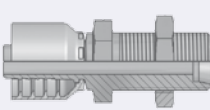
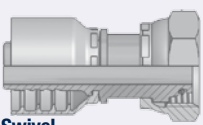
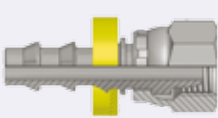
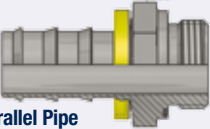

French Standard

<p>FG</p>  <p>Male French Gas Series Rigid – Straight (24° Cone)</p>	<p>F2</p>  <p>Female French Gas Series Swivel – 90° Elbow</p>	<p>F4</p>  <p>Female French Gas Series Swivel – Straight (Ball Nose)</p>	<p>F6</p>  <p>French Male Metric Series (24° Cone)</p>
<p>F9</p>  <p>French Female Metric Series Swivel – (Ball Nose)</p>	<p>FA</p>  <p>Metric Male for Agriculture Valves</p>		

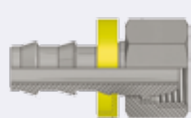
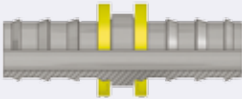
High Pressure Cleaning

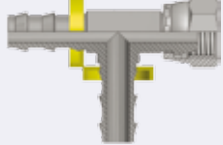
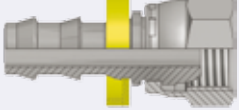
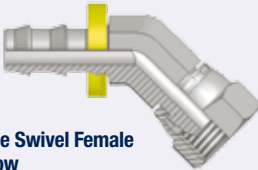
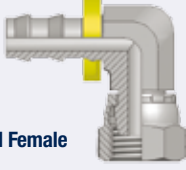
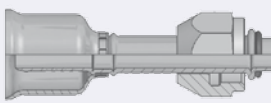
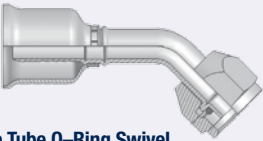
<p>CW</p>  <p>Power Cleaner Connection</p>	<p>NW</p>  <p>Female Kärcher Metric Cleaning Hose Fitting Swivel – Straight</p>	<p>PW</p>  <p>Male Kärcher Metric Cleaning Hose Fitting Rigid – Straight</p>
--	---	---

Others

<p>XU</p>  <p>Female Metric – Swivel Straight (30° Flare) JIS B8363</p>	<p>XY</p>  <p>Female Metric – Swivel 90° Elbow (30° Flare) JIS B8363</p>	<p>DK</p>  <p>Male Metric L – Rigid Bulkhead with Locknut (24° Cone)</p>	<p>DX</p>  <p>Female Metric Swivel (M27x2) O-Ring Light Series</p>
<p>FF</p>  <p>Metru-Lok Swivel Female</p>	<p>AF</p>  <p>Male BSP Parallel Pipe Rigid – Straight (with O-ring Seal)</p>	<p>NM</p>  <p>Male BSP Parallel Pipe L Series – Rigid – Straight ED-Seal ISO 1179</p>	<p>VW121</p>  <p>BSP Swivel Female (WW-Norm 39-V-16631)</p>
<p>82</p>  <p>Push-Lok® Union</p>	<p>DP</p>  <p>Metric Swivel Female Tee Male Stud</p>	<p>DR</p>  <p>Metric Swivel Female Tee</p>	<p>5C</p>  <p>60° Cone Swivel Female</p>
<p>6C</p>  <p>60° Cone Swivel Female 45° Elbow</p>	<p>7C</p>  <p>60° Cone Swivel Female 90° Elbow</p>	<p>5S</p>  <p>Female Tube O-ring Swivel Short Pilot</p>	<p>5H</p>  <p>Female Tube O-Ring Swivel 45° Elbow – Short Pilot</p>
<p>5T</p>  <p>Female Tube O-Ring Swivel 90° Elbow – Short Pilot</p>	<p>59PT</p>  <p>Male Tube O-Ring Swivel Long Pilot With Charge Port at 180° for R134a</p>	<p>5LPT</p>  <p>Female Tube O-Ring Swivel 90° Elbow – Long Pilot With Charge Port at 180° for R134a</p>	

UPTC Universal push-to-connect

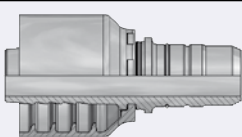
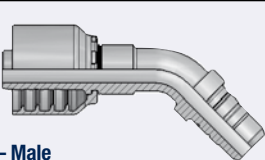
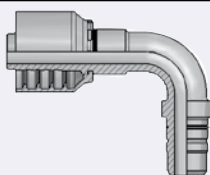
<p>EN</p>  <p>UPTC – Male Straight</p>	<p>EU</p>  <p>UPTC – Male 45° Elbow</p>	<p>ET</p>  <p>UPTC – Male 90° Elbow</p>
--	---	--

Hose Fittings Pressure Ratings

Fitting end connection	Description	Inch fittings (size) Maximum working pressure (MPa) – safety factor 4:1									
		-4	-5	-6	-8	-10	-12	-16	-20	-24	-32
92, B1, B2, B5	BSP swivel female	63.0		55.0	43.0	37.5	35.0	28.0	25.0	21.0	21.0
B4	BSP swivel female	35.0	35.0	35.0	35.0	35.0	35.0	28.0	25.0	21.0	21.0
EA, EB, EC	BSP swivel female with O-ring	40.0		40.0	35.0	35.0	31.5	25.0	20.0	16.0	12.5
91, D9	BSP male	63.0		55.0	43.0		35.0	28.0	25.0	21.0	21.0
01	NPTF male	34.5		27.5	24.0		21.0	17.0	15.0	14.0	14.0
02	NPTF female	34.5		27.5	24.0		21.0	17.0	15.0	14.0	14.0
03, 33	SAE (JIC) 37° male	41.0	41.0	34.5	34.5	34.5	34.5	27.5	20.0	17.0	17.0
04	SAE 45° male	41.0	41.0	34.5	34.5	34.5	34.5	27.5	20.0	17.0	17.0
05	SAE male with O-ring	41.0	41.0	34.5	34.5	34.5	34.5	27.5	20.0	17.0	17.0
06/68,37/3V, 39/3W, L9, 41/3Y	SAE (JIC) 37° swivel female	41.0	41.0	34.5	34.5	34.5	34.5	27.5	20.0	17.0	17.0
93	Female SAE (JIC) 37° 90° Elbow	41.4	41.0	34.5	34.5	34.5	34.5	27.5	20.0	17.0	17.0
07	Female NPSM-pipe swivel	34.5		27.5	24.0		21.0	17.0			
08, 77, 79	Female SAE 45° swivel	41.0	41.0	34.5	34.5	34.5	34.5	27.5	20.0	17.0	17.0
1L	Male NPTF pipe swivel 90° Elbow	21.0	21.0	21.0	21.0	19.0	15.5	14.0	11.0	9.0	8.0
S2	Female NPTF pipe swivel	21.0	21.0	21.0	21.0	19.0	15.5	14.0	11.0	9.0	8.0
0G, 0L	Male SAE O-ring	21.0	21.0	21.0	21.0	19.0	15.5	14.0	11.0	9.0	8.0
28, 67, 69	SAE Male inverted 45° swivel	19.0	17.0	15.0	14.0						
15, 16, 17, 18, 19, 26, 27, 89, X5, X7, X9	SAE flange Code 61				34.5	34.5	34.5	34.5	27.5	21.0	21.0
4A, 4N, 4F	SAE flange 5000 psi								34.5	34.5	34.5
6A, 6E, 6F, 6G, 6N, XA, XF, XG, XN, X5, X7, X9	SAE flange Code 62 6000 psi				41.0		41.0	41.0	41.0	41.0	41.0
8A, 8F, 8N	SAE flange 8000 psi					55.0	55.0	55.0	55.0		

Fitting end connection	Description	Inch fittings (size)									
		Maximum working pressure (MPa) – safety factor 4:1									
		-4	-5	-6	-8	-10	-12	-16	-20	-24	-32
JM, J6, J8, J0, JU	ORFS male	41.0		41.0	41.0	41.0	41.0	41.0	27.5	27.5	
JC, JS, J3, J7, J9, J5, J1	ORFS swivel female	41.0		41.0	41.0	41.0	41.0	41.0	27.5	27.5	
JD	Male ORFS Bulkhead with Locknut with O-ring	41.0		41.0	41.0	41.0	41.0	41.0	27.5	27.5	
GU	JIS / BSP swivel female 60° cone	35.0	35.0	35.0	35.0	28.0	28.0	21.0	17.5		
FU	Female JIS / BSP 30° parallel pipe swivel	35.0	35.0	35.0	35.0	28.0	28.0	21.0	17.5		
MU	JIS 30° metric swivel female	35.0	35.0	35.0	35.0	28.0	28.0	21.0	17.5		
MZ	Metric swivel female 90° Elbow	35.0	35.0	35.0	35.0	28.0	28.0	21.0	17.5		
UT	JIS / BSP male 60° cone	35.0		35.0	35.0		28.0	21.0	17.5		
V1	Banjo soft seal with UNF bolt	25.0	25.0		21.5	21.5	20.0				
V3	Banjo soft seal with BSPP bolt	25.0	25.0		21.5	21.5	20.0				
XU, XY	Female Metric swivel 30° Flare	35.0	35.0	35.0	35.0	28.0	28.0	21.0	17.5		

Fitting end connection	Description	Metric tube (mm) • Light series – L									
		Maximum working pressure (MPa) – safety factor 4:1									
		6	8	10	12	15	18	22	28	35	42
C3, C4, C5	Swivel female Form A	25.0	25.0	25.0	25.0	25.0	16.0	16.0	10.0	10.0	10.0
CA, CE, CF	DIN 20066 swivel female with O-ring, Form N	31.5	42.5	40.0	35.0	31.5	31.5	28.0	21.0	16.0	16.0
DO, DF, DG, DK	DIN 20066 male stud, Form D	25.0	42.5	40.0	35.0	31.0	28.0	28.0	21.0	16.0	16.0
DX	Metric swivel female with O-ring	31.5	42.5	40.0	35.0	31.5	31.5	28.0	21.0	16.0	16.0
1D, DD, 5D	Metric standpipe	25.0	25.0	25.0	25.0	25.0	16.0	16.0	10.0	10.0	10.0
CW, NW	High pressure cleaning hose connection					40.0					
PW	High pressure cleaning hose connection			22.5							
EN, ET, EU	Universal push-in connector		40.0	35.0	35.0	29.5	28.0	21.5			

Fitting end connection	Description	Metric tube (mm) • Very light series – LL									
		Maximum working pressure (MPa) – safety factor 4:1									
		8	10	12	15	18	22	28	35	42	50
C0	DIN 20066 swivel female DKLL						6.3	6.3	6.3	6.3	4.0

Fitting end connection	Description	Metric tube (mm) • Metric										
		Maximum working pressure (MPa) – safety factor 4:1										
		6	8	10	12	14	16	18	20	22	25	27
49	Metric Banjo - straight (DIN 7642)	20.0	20.0	20.0	20.0	20.0	20.0	20.0	20.0	20.0	20.0	
V2	Banjo soft seal with metric bolt				25.0	25.0		21.5		21.5		20.0

Fitting end connection	Description	Metric tube (mm) • Heavy series – S									
		Maximum working pressure (MPa) – safety factor 4:1									
		6	8	10	12	14	16	20	25	30	38
C6, C7, C8	Swivel female	63.0	63.0	63.0	63.0	63.0	40.0	40.0	40.0	25.0	25.0
C9, 0C, 1C	Swivel female DIN 20066:2002-10 with O-ring, Form P	63.0	63.0	63.0	63.0	63.0	42.0	42.0	42.0	42.0	42.0
D2	Male stud	63.0	63.0	63.0	63.0	63.0	42.0	42.0	42.0	42.0	42.0
3D	Metric standpipe	63.0	63.0	63.0	63.0	63.0	40.0	40.0	40.0	25.0	25.0

Fitting end connection	Description	Metric tube (mm) • French gas series				
		Maximum working pressure (MPa) – safety factor 4:1				
		13	17	21	27	33
F2	Swivel female 90° Elbow	36.0	27.0	25.5	20.0	17.0
F4	Swivel female (Ball Nose)	36.0	27.0	25.5	20.0	17.0
FG	Male stud	36.0	27.0	25.5	20.0	17.0
GE	Metric standpipe	36.0	27.0	25.5	20.0	17.0

Fitting end connection	Description	Metric tube (mm) • French metric series						
		Maximum working pressure (MPa) – safety factor 4:1						
		10	12	14	18	20	22	30
F9	Swivel female	20.0		14.0	16.0	14.0	13.0	12.2
F6	Male agricultural valves	20.0		14.0	16.0	14.0	13.0	12.2
FA	Male agricultural valves		25.0					

Hose Fittings Nomenclature

End Configuration	Description	Standards	Common Terms
01	Male NPTF Pipe – Rigid – Straight	SAE J476A / J516	AGN
02	Female NPTF Pipe – Rigid – Straight	SAE J476A / J516	
03	Male JIC 37° – Rigid – Straight	ISO12151-5-S	AGJ
04	Male SAE 45° – Rigid – Straight	SAE J516	
05	Male SAE Straight Thread with O-ring – Rigid – Straight	ISO 11926, SAE J516	
06	Female JIC 37° Swivel – Straight	ISO12151-5-SWS	DKJ
06/68	Female – JIC 37° / SAE 45° Dual Flare – Swivel – Straight	ISO12151-5-SWS	DKJ
07	Female NPSM Pipe Swivel		
08	Female SAE 45° – Swivel – Straight	SAE J516	
0C	Female Metric 24° – Heavy Series with O-ring – Swivel – 45° Elbow	ISO 12151-2 – SWE 45°-S	DKOS 45°
0G	Male O-ring Straight		
0L	Male O-ring 90° Elbow		
11	„Ferrul-Fix“		
12	Female SAE Flareless Swivel – Straight (24° Cone)		
13	Male NPTF Pipe Swivel	SAE J476A / J516	
15	SAE Code 61 – Flange Head – Straight	ISO 12151-3-S-L	SFL / 3000 psi
15/4A	SAE Code 61 – Flange Head – Straight / SAE Flange Head 5000 psi	ISO 12151-3-S-L	SFL
16	SAE Code 61 – Flange Head – 22.5° Elbow	ISO 12151-3-E22ML	SFL 22.5° / 3000 psi
17	SAE Code 61 – Flange Head – 45° Elbow	ISO 12151-3 – E45 – L	SFL 45° / 3000 psi
17/4F	SAE Code 61 – Flange – 45° Elbow – 45° Elbow (5000 psi)	ISO 12151-3 – E45S – L	SFL 45°
18	SAE Code 61 – Flange – 67.5° Elbow		SFL 67.5°
19	SAE Code 61 – Flange Head – 90° Elbow	ISO 12151-3 – E– L	SFL 90° / 3000 psi
19/4N	SAE Code 61 – Flange Head – 90° Elbow (5000 psi)	ISO 12151-3-E-L	SFL 90°
1C	Female Metric 24° – Heavy Series with O-ring – Swivel – 90° Elbow	ISO 12151-2-SWE-S	DKOS 90°
1D	Metric Standpipe – Light Series – Rigid – Straight	ISO 8434-1	BEL
1L	Male NPTF Pipe Swivel – 90° Elbow		
26	SAE Code 61 Flange – 30° Elbow		SFL 30°
27	SAE Code 61 Flange – 60° Elbow		SFL 60°
28	SAE Male Inverted 45° Elbow		
33	Male JIC 37° – Rigid – 45° Elbow	ISO 12151-5	AGJ 45°
34	Inch Standpipe (Brass)		
37	Female JIC 37° – Swivel – 45° Elbow	ISO 12151-5-SWE 45°	DKJ 45°
37/3V	Female JIC 37° /SAE 45° – Dual Flare – Swivel Female 45° Elbow	ISO 12151-5-SWE 45°	DKJ 45°
39	Female JIC 37° – Swivel – 90° Elbow	ISO 12151-5-SWES	DKJ 90°
39/3W	Female JIC 37° / SAE 45° – Dual Flare – Swivel Female 90° Elbow	ISO 12151-5-SWES	DKJ 90°
3D	Metric Standpipe – Heavy Series – Rigid – Straight	ISO 8434-1	BES
3V	Female JIC 37°/SAE – 45° Swivel – 45° Elbow		DKJ 45°
3W	Female JIC 37°/SAE – 45° Swivel – 90° Elbow		DKJ 90°
3Y	Female JIC 37°/SAE – 45° Swivel – 90° Elbow (Long)		DKJ 90°
41	Female JIC 37° Swivel – 90° Elbow (Long)		DKJ 90°
41/3Y	Female JIC 37° / 45° Swivel Female 90° Elbow (Long)	ISO 12151-5-SWEL	DKJ 90°L
45	Male Tube O-ring Swivel – Long Pilot		

End Configu-ration	Description	Standards	Common Terms
49	Metric Banjo – Straight	DIN 7642	
4A	5000 psi SAE Code 61 – Flange – Straight		
4F	5000 psi SAE Code 61 – Flange – 45° Elbow		
4N	5000 psi SAE Code 61 – Flange – 90° Elbow		
59	Female Tube O-ring Swivel – Long Pilot		
59PT	Male Tube O-ring Swivel – Long Pilot	With Charge Port at 180° for 134a	
5C	60° Cone Swivel Female		
5D	Metric Standpipe – Light Series – Rigid – 90° Elbow	ISO 8434-1	BEL 90°
5G	Male Tube O-ring Rigid Port (3 step) Straight		
5GPR	Female Tube O-ring Rigid Port (3 step) Straight	With Charge Port for R12	
5H	Female Tube O-ring Swivel – 45° Elbow – Short Pilot		
5K	Male Tube O-ring Swivel – 90° Elbow – Short Pilot		
5LPR	Female Tube O-ring Swivel – 90° Elbow – Long Pilot		
5LPT	Female Tube O-ring Swivel – 90° Elbow – Long Pilot	With Charge Port at 180° for 134a	
5MPR	Male Tube O-ring Swivel – 90° Elbow – Long Pilot	With Charge Port at 180° for R12	
5MPV	Male Tube O-ring Swivel – 90° Elbow – Long Pilot	With Charge Port at 270° for 134a	
5N	Female Tube O-ring Swivel – 45° Elbow – Long Pilot		
5P	Female Tube O-ring Swivel – 45° Elbow – Long Pilot		
5R	Male Tube O-ring Swivel – 45° Elbow – Short Pilot		
5S	Female Tube O-ring Swivel – Short Pilot		
5T	Female Tube O-ring Swivel – 90° Elbow – Short Pilot		
5V	Female Compressor – Swivel 45° Elbow		
5W	Female Compressor – Swivel 90° Elbow		
5Z	Female Compressor – Swivel 90° Elbow – Block Type		
67	SAE Male Inverted Flare Swivel – 45° Elbow		
68	Female JIC 37° / SAE 45° Swivel		DKJ
69	SAE Male Inverted Flare Swivel – 90° Elbow		
6A	SAE Code 62 – Flange – Straight	ISO 12151-3-S-S	SFS / 6000 psi
6B	SAE Code 62 – Flange – 22.5° Elbow		SFS 22.5°
6C	60° Cone Swivel Female – 45° Elbow		
6E	SAE Code 62 – Flange – 30° Elbow		SFS 30°
6F	SAE Flange 45° Elbow – Heavy Series	ISO 12151-3 – E45-S	SFS 45° / 6000 psi
6G	SAE Code 62 – Flange – 60° Elbow		SFS 60°
6N	SAE Code 62 – Flange – 90° Elbow	ISO 12151-3 – E-S	SFS 90° / 6000 psi
77	Female SAE 45° Swivel – 45° Elbow		
79	Female SAE 45° Swivel – 90° Elbow		
7C	60° Cone Swivel Female – 90° Elbow		
7D	Male Standpipe Metric S – Rigid – 90° Elbow		BES 90°
82	Push-Lok® Union		
89	SAE Code 61 – Flange – 90° Elbow (Long) – Standard Series		
8A	Flange – Straight – 8000 psi		
8F	Flange – 45° Elbow – 8000 psi		
8N	Flange – 90° Elbow – 8000 psi		
91	Male BSP Taper Pipe – Rigid – Straight	BS5200	AGR-K

End Configuration	Description	Standards	Common Terms
92	Female BSP Parallel Pipe – Swivel – Straight (60° Cone)	BS5200-A	DKR
93	Female JIC 37° – Swivel – 90° Elbow (Block Type)		
9B	Metric – Swivel Female 45° Elbow – Light Series		
9C	Light Series Metric Swivel Female 90° Elbow		
AF	Male BSP Parallel Pipe – Rigid – Straight (with O-ring Seal)		
B1	Female BSP Parallel Pipe – Swivel – 45° Elbow (60° Cone)	BS 5200-D	DKR 45°
B2	Female BSP Parallel Pipe – Swivel – 90° Elbow (60° Cone)	BS 5200-B	DKR 90°
B4	Female BSP Parallel Pipe – Swivel – 90° Elbow Block Type (60° Cone)	BS 5200-E	DKR 90°
B5	Female BSP Parallel Pipe – Swivel – Straight (Flat Seat)		
C0	Female Metric – Very Light Series LL – Swivel – Straight (Ball Nose)		DKM
C3	Female Metric – Light Series – Swivel – Straight (Ball Nose)		DKL
C4	Female Metric – Light Series – Swivel – 45° Elbow (Ball Nose)		DKL 45°
C5	Female Metric – Light Series – Swivel – 90° Elbow (Ball Nose)		DKL 90°
C6	Female Metric – Heavy Series – Swivel – Straight (Ball Nose)		DKS
C7	Female Metric Swivel – 45° Elbow “Heavy” Series		DKS 45°
C8	Female Metric Swivel – 90° Elbow “Heavy” Series		DKS 90°
C9	Female Metric 24° – Heavy Series with O-ring – Swivel – Straight	ISO 12151-2-SWS-S	DKOS
CA	Female Metric 24° – Light Series with O-ring – Swivel – Straight	ISO 12151-2-SWS-L	DKOL
CE	Female Metric 24° – Light Series with O-ring – Swivel – 45° Elbow	ISO 12151-2-SWE 45°-L	DKOL 45°
CF	Female Metric 24° – Light Series with O-ring – Swivel – 90° Elbow	ISO 12151-2-SWE-L	DKOL 90°
CW	Power Cleaner Connection		
D0	Male Metric 24° – Light Series – Rigid – Straight	ISO 12151-2-S-L	CEL
D2	Male Metric 24° – Heavy Series – Rigid – Straight	ISO 12151-2-S-S	CES
D9	Male BSP Parallel Pipe – Rigid – Straight (60° Cone)	BS5200	AGR
DD	Metric Standpipe – Light Series – Rigid – 45° Elbow		BEL 45°
DE	Double Banjo Union		
DK	Male Metric L – Rigid – Bulkhead with Locknut (24° Cone)		
DP	Metric Swivel Female Tee / Male Stud		
DR	Metric Swivel Female Tee		
DS	Metric Swivel Female Tee / Standpipe		
DW	Female Metric Swivel „Light“ Series		TGL
DX	Female Metric Swivel (M27x2) O-ring – Light Series		
EA	BSP Swivel Female with O-ring (60° Cone)	BS 5200, ISO 12151-6	DKOR
EB	BSP Swivel Female with O-ring – 45° Elbow (60° Cone)	BS 5200, ISO 12151-6	DKOR 45°
EC	BSP Swivel Female with O-ring – 90° Elbow (60° Cone)	BS 5200, ISO 12151-6	DKOR 90°
EN	UPTC – Male – Straight		
ET	UPTC – Male – 90° Elbow		
EU	UPTC – Male – 45° Elbow		
F2	Female French Swivel Female – Gas Series 90° Elbow		
F4	Female French Gas Series – Swivel – Straight (Ball Nose)		
F6	French Male Metric Series (24° Cone)		
F9	French Swivel Female Metric Series – (Ball Nose)		
FA	Metric Male For Agriculture Valves		
FB	French Metric		

End Configu- ration	Description	Standards	Common Terms
FF	Metru-Lok Swivel Female		
FG	Male French Gas Series – Rigid – Straight (24° Cone)		
FU	Female BSP Parallel Pipe – Swivel – Straight (30° Flare)	ISO 228-1, JIS B8363	GUI
GE	French Gas Standpipe		
GU	Female BSP Parallel Pipe – Swivel – Straight (60° Cone)	ISO 228-1, JIS B8363	GUO
J1	Female ORFS – Swivel – 90° Elbow – Long Drop	ISO 12151-1 – SWEL, SAE J 516	ORFS 90° L
J5	Female ORFS – Swivel – 90° Elbow – Medium Drop	ISO 12151-1 – SWEM	ORFS 90° M
J7	Female ORFS – Swivel – 45° Elbow	ISO 12151-1 – SWE 45°, SAE J516	ORFS 45°
J9	Female ORFS – Swivel – 90° Elbow – Short Drop	ISO 12151-1 – SWES, SAE J516	ORFS 90°
JC	Female ORFS – Swivel – Straight – Short	ISO 12151-1 – SWSA, SAE J516	ORFS
JD	Male ORFS – Bulkhead with Locknut – Straight (with O-ring)	ISO 12151-1 – SAE J516	
JM	ORFS Male	ISO 12151-1-S, SAE J516	
JS	ORFS Swivel Female (Long)	ISO 12151-1-SWSB, SAE J516	ORFS
L9	Female JIC 37° – Swivel – 90° Elbow – Medium Drop	ISO 12151-5-SWEM	DKJ 90° M
MU	Female Metric – Swivel – Straight (30° Flare)	JIS B8363	MU
MZ	Female Metric – Swivel – 90° Elbow (30° Flare)	JIS B8363	
NM	Male BSP Parallel Pipe – L Series – Rigid – Straight – ED-Seal	ISO 1179	
NW	Female Kärcher Metric Cleaning Hose Fitting – Swivel – Straight		
PW	Male Kärcher Metric Cleaning Hose Fitting – Rigid – Straight		
PY	Flange – 24° Male – French Gas – Straight		
S2	Female NPTF Pipe Swivel		
S5	Male Tube O-ring Swivel – Short Pilot		
T1	Male Refrigerant Tube Mender – Straight (with Nut and Ferrule)		
UT	Male BSP Taper Pipe – Rigid – Straight (60° Cone)	JIS B 8363-R	
V1	Ermeto standard Pressure Banjo – Straight (with UNF Bolt and O-ring)		
VW	Push In Connector	(VW-Standard 39-V-16619)	
VW121	BSP Swivel Female	(VW-Norm 39-V-16631)	
VW39D	Push In Connector	(VW-Standard 39D-1401)	
WKS	Rubber hand grip		
X5	Flange – Straight – Full flange system for Code 61 or Code 62		
X7	Flange – 45° Elbow – Full flange system for Code 61 or Code 62		
X9	Flange – 90° Elbow – Full flange system for Code 61 or Code 62		
XA	Caterpillar® Flange Head – Straight		
XF	Caterpillar® Flange Head – 45° Elbow		
XG	Caterpillar® Flange Head – 60° Elbow		
XN	Caterpillar® Flange Head – 90° Elbow		
XU	Female Metric – Swivel – Straight (30° Flare)	JIS B8363	
XY	Female Metric – Swivel – 90° Elbow (30° Flare)	JIS B8363	
YW	Male Standpipe – Rigid – Straight – A-Lok	Metric Size Tube O.D. with Vee Notch	

Classification Bodies

The mission of classification bodies is to contribute to the development and implementation of technical standards for the protection of life, property and the environment.

(1) Germanischer Lloyd (GL)

German independent organisation of technical experts approving products for the German mercantile marine and the energy sector – GLIS (oil and gas, wind energy, etc...)

(2) Det Norske Veritas (DNV)

Norwegian service company for managing risk in ship classification, off-shore industry, etc...

(3) RINA (Registro Italiano Navale)

Italian company offering certification, verification, control, assistance in marine, energy & process, transport and industry.

(4) Deutsche Bahn (DB) - German Standard DIN 5510 - Part 2

The German rail authority (DB) approves the behaviour of products with respect to their resistance to burning and their ability to self-extinguish after a fire, according the DIN 5510-2 requirements.

(5) Lloyd's Register (LR)

English independent organisation providing certification around the world. Marine services, Rail services and Energy services are their main activities.

(6) Ministry of Defence (MOD)

British Ministry of Defence providing approvals for military equipment according the MOD DefStan (Defence Standard) 47-2 specification.

(7) American Bureau of Shipping (ABS)

US company providing rules for safety in the marine environment.

(8) US Department of Transportation (DOT)

US organisation providing certifications to ensure a fast, safe, efficient, accessible and convenient transportation system in this country.

(9) US Coast Guard (USCG)

Provides maritime safety, law enforcement, recreational boating safety, and environmental protection information for merchant mariners. The approved hoses are not accepted for all applications automatically. If the column contains "H", the hose is accepted for hydraulic systems only and not for fuel and lube systems.

(10) Mine Safety and Health Administration (MSHA)

US organisation for safety in the mining industry

(11) French Standard NF F-16-101/102 (NF)

Tests the fire behaviour and fire effluents of the hose cover material for rail applications.

(12) British Standard (BS 6853)

Tests the fire behaviour and fire effluents of the hose cover material for rail applications.

(13) MarED

MarED is the Group of Notified Bodies for the Implementation of the Marine Equipment Directive.

(14) UNI CEI 11170-1:2005

Railway and tramway vehicles
– Guidelines for fire protection of railway, tramway and guided path vehicles

(15) Bureau Veritas (BV)

Bureau Veritas is today the most widely recognized certification body in the world, offering solutions in the key strategic fields of operations: Quality, Health & Safety, Environment and Social Responsibility.

(16) GIG

The Central Mining Institute (in Polish: Główny Instytut Górnictwa GIG) is a restructured scientific and development organization, subordinated to the Minister of Economy, working not only for the benefit of the mining industry, but also for enterprises representing different branches - including small and medium enterprises, state and local administration institutions and offices, and foreign partners.

(17) Verteidigungs-Gerätenorm (VG)

German Organisation providing approvals for military equipment.

EN	European Standard
ISO	International Organisation for Standardization
SAE	Society of Automotive Engineers (US organisation)

Description (1)-(17) see Ab-15

Classification Body Type Approvals

Hose	Construction	Standard	GL (1)	DNV (2)	RINA (3)	DB/DIN 5510 (4)	LR (5)	MOD (6)	ABS (7)	DOT (8)	USCG (9)	MSHA (10)	NF (11)	BS 6853 (12)	MarED (13)	UNI CEI (14)	BV Marine (15)	GIG (16)	VG (17)	Low pressure		
																				Push-Lok	Transport + Hydraulic	Medium pressure
Multipurpose	801Plus	1 braid, fibre																				
	830M	1 braid, fibre																				
	831	1 braid, fibre																				
	837BM	1 braid, fibre																				
	837PU	1 braid, fibre																				
	804	1 braid, fibre																				
	821FR	1 braid, fibre																				
	836	1 braid, fibre											X									
	838M	1 braid, fibre																				
	Standard	601	2 braids, fibre																			
611		1 braid, fibre																				
681		2 braids, fibre																				
High temperature	611HT	1 braid, fibre																				
	681DB	2 braids, fibre					X						X									
Transportation	201	1 braid, wire								X												
	206	1 braid, wire								X												
	213	1 braid, wire								X												
	293	1 braid, fibre								X												
Fire retardant	221FR	1 braid, wire	X	X					X													
	285	1 braid, wire																				
Refrigeration	4215N	1 braid, wire	X	X	X		X		X											X	X	
	422	1 braid, wire																		X	X	
	3015N	2 braids, wire	X	X	X		X		X											X	X	
	302	2 braids, wire																			X	
Standard	441	1 braid, wire																				
	451	1/2braid, wire								X												
	492	1 braid, wire	X	X	X		X								X							
	462	2 braids, wire	X	X	X		X								X							
	301TC	2 braids, wire																		X		
	351TC	2 braids, wire																				
High abrasion resistance MSHA approved	451TC	1/2braid, wire										X										
	471TC	2 braids, wire										X										
	472TC	2 braids, wire		X					X			X										
	4925T	1 braid, wire																				
Extreme abrasion resistance	4625T	2 braids, wire																				
	426	1 braid, wire							X													
Low / High temperature	436	2 braids, wire							X													
	461LT	2 braids, wire		X																		
Phosphate Ester	424	1 braid, wire																				
	304	2 braids, wire																				

Hose	Construction	Standard	GL (1)	DNV (2)	RINA (3)	DB/DIN 5510 (4)	LR (5)	MOD (6)	ABS (7)	DOT (8)	USCG (9)	MSHA (10)	NF (11)	BS 6853 (12)	MarED (13)	UNI CEI (14)	BV Marine (15)	GG (16)	VG (17)	Medium pressure		
																				3-braids	High pressure	
																				High pressure		
																				3-braids	Parkrimp No-Skive	ParLock
Railway	441RH	1 braid, wire	ISO 11237-R16 - SAE 100R16			X							X	X		X						
Water cleaning	421RH	1 braid, wire	DIN EN 853-1SN - ISO 1436-1SN/R1AT - SAE 100R1AT			X							X	X								
	493	1 braid, wire	-																			
Pilot	463	2 braids, wire	-																			
	402	1 braid, wire	-																			
Wire cover	412	1 braid, wire	-																			
	421WC	1 braid, wire	ISOS1436-1SN/R1AT - SAE 100R1AT																			
Powerlift	477	2 braids, wire	Excels DIN EN 853-2SN - DIN EN 856-2SC																			
	4775T	2 braids, wire	Excels DIN EN 853-2SN - DIN EN 856-2SC																			
Extremely flexible	692	1/2 braids, wire	Excels SAE 100R17																			
	692Twin	1/2 braids, wire	Excels SAE 100R17																			
Suction	811	1 braid, 1steelspiral	SAE 100R4								H	X										
	881	1 braid, 1steelspiral	SAE 100R4																			
Standard	372	3 braids, wire	-	X			X															
Low temperature	371LT	3 braids, wire	-																			
High abrasion res.	372TC	3 braids, wire	-									X										
Railway	372RH	3 braids, wire	-			X							X	X								
Standard	701	4 spiral, wire	DIN EN 856-4SP - ISO 3862-4SP	X																		
	731	4 spiral, wire	DIN EN 856-4SH - ISO 3862-4SH																			
Standard	781	4/6 spiral, wire	DIN EN 856-R13 - ISO 3862-R13 - SAE 100R13																			
	P35	6 spiral, wire	DIN EN 856-R13 - ISO 3862-R13 - SAE 100R13		X				X		X	X										
Phosphate Ester	774	4 spiral, wire	-																			
Extreme pressure	F42	4/6 spiral, wire	ISO 3862-R15 - SAE 100R15																			
	761	6 spiral, wire	-																			
High abrasion resistance	721TC	4 spiral, wire	DIN EN 856-R12 - ISO 3862-R12 - SAE 100R12									X										
	782TC	4/6 spiral, wire	DIN EN 856-R13 - ISO 3862-R13 - SAE 100R13		X				X			X										
MSHA approved	791TC	4/6 spiral, wire	ISO 3862-R15 - SAE 100R15		X				X		X	X										
	792TC	4/6 spiral, wire	ISO 3862-R15 - SAE 100R15		X				X		H	X										
Low temperature	772LT	4 spiral, wire	DIN EN 856-R12 - ISO 3862-R12 - SAE 100R12																			
Compact spiral !	787TC	4/6 spiral, wire	SAE 100R13 - ISO 3862 Type R13 - ISO 18752-DC									X										
	797TC	4/6 spiral, wire	SAE 100R15 - ISO 3862 Type R15 - ISO 18752-DC									X										
Standard	H31	4 spiral, wire	Excels DIN EN 856-4SP - ISO 3862-4SP	X	X				X						X		X					
	H29	4 spiral, wire	Excels DIN EN 856-4SH - ISO 3862-4SH	X	X				X						X		X					
High abrasion resistance	R35	4/6 spiral, wire	DIN EN 856-R13 - ISO 3862-R13 - SAE 100R13																			
	R42	4/6 spiral, wire	ISO 3862-R15 - SAE 100R15	X	X				X						X							
Extreme abrasion resistance	H31TC	4 spiral, wire	Excels EN 856-4SP - ISO 3862-4SP									X										
	H29TC	4 spiral, wire	Excels EN 856-4SH - ISO 3862-4SH									X										
MSHA approved	R35TC	4/6 spiral, wire	DIN EN 856-R13 - ISO 3862-R13 - SAE 100R13									X										
	R42TC	4/6 spiral, wire	ISO 3862-R15 - SAE 100R15									X										
Extreme abrasion resistance	R50TC	4/6 spiral, wire	Excels ISO 3862 Type R15									X										
	H315T	4 spiral, wire	Excels DIN EN 856-4SP - ISO 3862-4SP									X										
Railway	H295T	4 spiral, wire	Excels DIN EN 856-4SH - ISO 3862-4SH									X										
	R425T	4/6 spiral, wire	ISO 3862-R15 - SAE 100R15									X										
Railway	H29RH	4 spiral, wire	Excels DIN EN 856-4SH - ISO 3862-4SH										X									

Conversion Chart

	Unit	Base Unit	Conversion Unit	Factor
Length	1 inch	in	mm	25.4
	1 millimetre	mm	in	0.03934
	1 foot	ft	m	0.3048
	1 metre	m	ft	3.28084
Area	1 square inch	sq in	cm ²	6.4516
	1 square centimetre	cm ²	sq in	0.1550
Volume	1 gallon (UK)	gal	l	4.54596
	1 litre	l	gal (UK)	0.219976
	1 gallon (US)	gal	l	3.78533
	1 litre	l	gal (US)	0.264177
Weight	1 pound	lb	kg	0.453592
	1 kilogramme	kg	lb	2.204622
Torque	1 pound foot	lb • ft	kg • m	1.488164
	1 Newton metre	kg • m	lb • ft	0.671969
Pressure	1 pound per square inch	psi	bar	0.06895
	1 bar	bar	psi	14.5035
	1 pound per square inch	psi	MPa	0.006895
	1 mega pascal	MPa	psi	145.035
	1 kilo pascal	kPa	bar	0.01
	1 bar	bar	kPa	100
	1 mega pascal	MPa	bar	10
	1 bar	bar	MPa	0.1
Velocity	1 foot per second	ft / s	m / s	0.3048
	1 metre per second	m / s	ft / s	3.28084
Flow rate	1 gallon per minute (UK)	gal / min.	l / min.	4.54596
	1 litre per minute	l / min.	gal / min. (UK)	0.219976
	1 gallon per minute (US)	gal / min.	l / min.	3.78533
	1 litre per minute	l / min.	gal / min. (US)	0.264178
Temperature	Fahrenheit degree	°F	°C	5/9 • (°F-32)
	Celsius degree	°C	°F	°C • (9/5) +32

(UK) Unit of United Kingdom
 (US) Unit of USA

Temperature / Pressure Chart

Reference 201, 206, 213 and 293 hose.

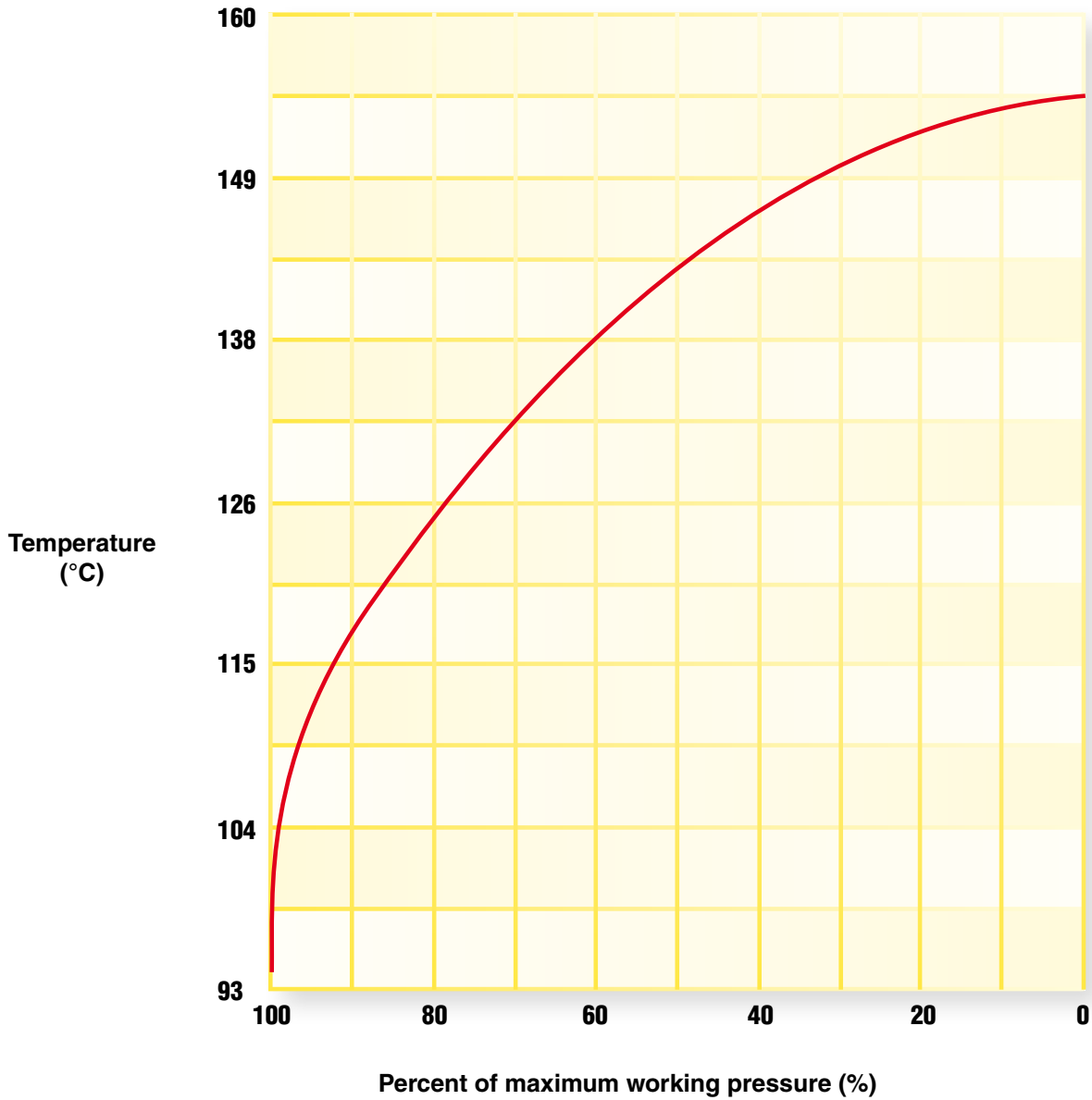

EXAMPLE: 201-8 hose to be used at 121 °C

Maximum Working Pressure up to 100 °C	x	Multiplication Factor from Chart	=	Maximum Working Pressure at 121 °C
13.8 MPa (2000 psi)	x	85%	=	11.7 MPa (1700 psi)

Flow Capacity Nomogram

The chart below is provided as an aid in the determination of the correct hose size.

Example: at 10 gallons per minute (gal/min), what is the proper hose size within the recommended velocity range for pressure lines?

Locate 10 gallons per minute in the left-hand column and 20 feet per second in the right-hand column (the maximum recommended velocity range for pressure lines). Lay a straight line across these two points.

The inside diameter shown in the centre column is above -6 so we have to use -8 (1/2"). For suction hose, follow the same procedure except use recommended velocity range for intake lines in the right-hand column.

- where: Q = flow in gallons per minute (gal/min & l/min)
- V = velocity in feet per second (f/s & m/s)
- d = hose inside diameter (mm & dash size)

Example
 Flow Q = 45 l/m
 Velocity V = 6,1 m/s
 Konstant K = 21,2025

$$D = \sqrt{\frac{Q * K}{V}} = \sqrt{\frac{45 \frac{l}{m} * 21,2025}{6,1 \frac{m}{s}}} = 12,5 \text{ mm}$$

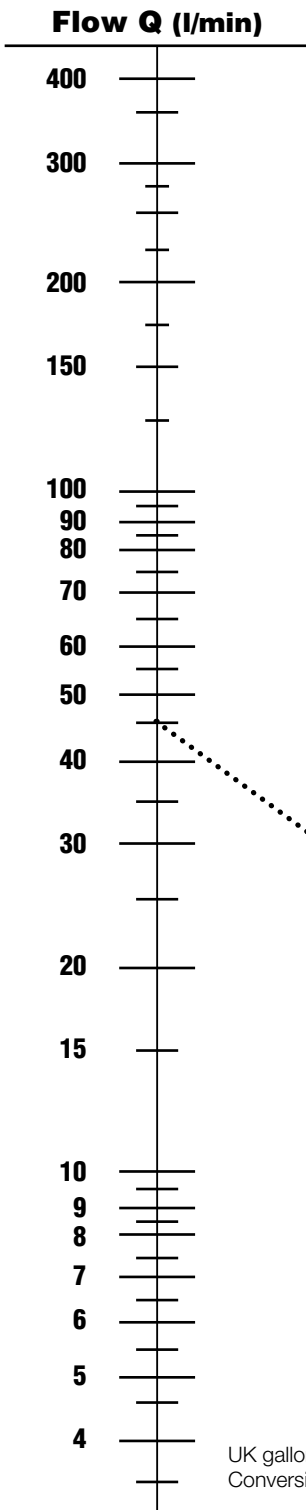

Inside diameter d	
mm	dash sizes inch
50,8	-32 2
38,1	-24 1-1/2
31,8	-20 1-1/4
25,4	-16 1
19,1	-12 3/4
15,9	-10 5/8
12,7	-8 1/2
9,5	-6 3/8
7,9	-5 5/16
6,3	-4 1/4
4,8	-3 3/16

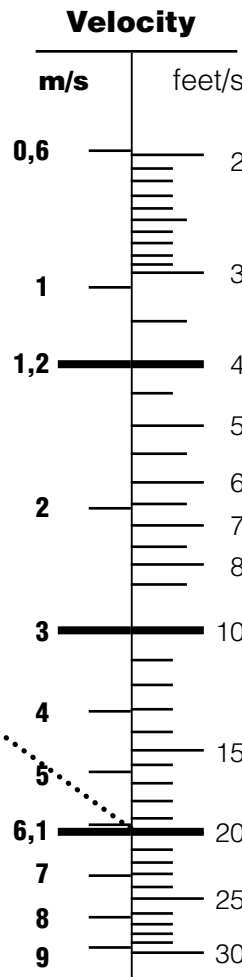

Recommended maximum velocity for suction lines

Recommended maximum velocity for return lines

Recommended maximum velocity for pressure lines

UK gallons
 Conversion factor: gal/min x 4,546 = l/min
 feet/s x 0,3048 = m/s

* Recommended velocities are according to hydraulic fluids of maximum viscosity 315 S.S.U. at 38°C working at roomtemperature within 18° and 68°C.

The Correct Method to Fit Female Swivel Ends

To ensure a leakproof seal between swivel female hose ends shown in this catalogue and the appropriate adaptors it is necessary to follow the procedure below which is different from hydraulic tube assembly.

Flats From Wrench Resistance (FFWR)

Parker's recommended assembly method for JIC 37° flare, SAE 45° flare and ORFS swivel female is Flats From Wrench Resistance (FFWR). The torque values assigned by size are for reference only, and are only



applicable to Parker system components using the FFWR method with trivalent chromate passivation on zinc plating of carbon steel components without lubrication.

Metal-to-metal seal



Screw the nut up hand tight and then tighten further with a spanner according to the values mentioned in the table below. Ensure that in all cases the hose is correctly aligned before tightening the nut onto the corresponding adaptor.

Spanner torque values

Metric swivel female

			
		nominal	min. - max.
M 12x1.5	06L	16	15 - 17
M 14x1.5	08L	16	15 - 17
M 16x1.5	10L	26	25 - 28
M 18x1.5	12L	37	35 - 39
M 22x1.5	15L	47	45 - 50
M 26x1.5	18L	89	85 - 94
M 30x2	22L	116	110 - 121
M 36x2	28L	137	130 - 143
M 45x2	35L	226	215 - 237
M 52x2	42L	347	330 - 363
M 14x1.5	06S	26	25 - 28
M 16x1.5	08S	42	40 - 44
M 18x1.5	10S	53	50 - 55
M 20x1.5	12S	63	60 - 66
M 22x1.5	14S	79	75 - 83
M 24x1.5	16S	84	80 - 88
M 30x2	20S	126	120 - 132
M 36x2	25S	179	170 - 187
M 42x2	30S	263	250 - 275
M 52x2	38S	368	350 - 385

BSP swivel female

	size		
		nominal	min. - max.
G1/4	-4	20	15 - 25
G3/8	-6	34	27 - 41
G1/2	-8	60	42 - 76
G5/8	-10	69	44 - 94
G3/4	-12	115	95 - 135
G1	-16	140	115 - 165
G1-1/4	-20	210	140 - 280
G1-1/2	-24	290	215 - 365
G2	-32	400	300 - 500

Note

Values given in tables are typical to achieve the recommended assembly methods when fitting material is steel zinc plated. For other materials different values will be applicable (see our recommendations for other materials on this page).

JIC 37° swivel female

	size	Flats From Wrench Resistance (FFWR)	Swivel Nut Torque Nm (Ref)
7/16-20	-4	2	18
1/2-20	-5	2	23
9/16-18	-6	1-1/2	30
3/4-16	-8	1-1/2	57
7/8-14	-10	1-1/2	81
1.1/16-12	-12	1-1/4	114
1.5/16-12	-16	1	160
1.5/8-12	-20	1	228
1.7/8-12	-24	1	265
2.1/2-12	-32	1	360

ORFS swivel female

	size	Flats From Wrench Resistance (FFWR)	Swivel Nut Torque Nm (Ref)
9/16-18	-4	1/2 to 3/4	25
11/16-16	-6	1/2 to 3/4	40
13/16-16	-8	1/2 to 3/4	55
1-14	-10	1/2 to 3/4	80
1.3/16-12	-12	1/3 to 1/2	115
1.7/16-12	-16	1/3 to 1/2	150
1.11/16-12	-20	1/3 to 1/2	205
2-12	-24	1/3 to 1/2	315
2-1/2x12	-32	-	-

Note: The assembly torques listed are higher than the test torques published in SAE J1453.

The torque values for other materials are as follows:

- Brass fittings and adapters
 - 65 % of the torque value for steel.
- Stainless steel and Monel
 - Use 5% higher than listed for steel.
 - Threads to be lubricated for these materials.
- Dissimilar metals
 - Use torque value designated for the lower of the two metals.
- All fittings are dry except as noted above.

Chemical Resistance Table

Warning ! This chemical compatibility guide must not be used in conjunction with any other compatibility guides from previous or future catalogue editions, bulletins or publications. Incorrect use of these charts could result in death, personal injury or property damage.

Hose Selection by Medium and Hose Type

This hose compatibility chart is a ready reference of Parker hose compatibility with various fluid media. It is intended as a guide to chemical compatibility with inner tube materials and assembly lubricants applied internally.

The outer cover of the hose is intended to protect the reinforcement layer(s) from mechanical influences (abrasion, weathering etc), as such the cover compounds are not designed to exhibit the same chemical resistance as the tube compounds. The Hose Division Technical Department should be consulted about the compatibility of the cover should the application involve the extended exposure or immersion in a liquid.

The specific recommendations are based upon field experience, the advice of various polymer or fluid suppliers, and specific laboratory experiments. It must be stressed, however, that this information is offered only as a guide. Final hose selection depends also upon pressure, fluid temperature, ambient temperature, and special requirements or variations, which may not be known by Parker. Legal and other regulations must be followed with particular care.

Where an external compatibility problem may occur, or for fluids not listed, we encourage you to first contact the fluid manufacturer for a recommendation prior to contacting your Parker Field Representative or the Technical Department, Hose Products Division Europe (HPDE_Helpdesk@parker.com)

Use the Chart as Follows:

1. Locate medium to be carried using the Chemical Resistance Table on the following pages.
2. Select suitability of hose and fitting material from the table based on the letter rating in the table. See resistance rating key below for explanation of compatibility ratings. See list of numerals below for an explanation when a numeral, or a numeral and a letter rating are present in the table.
3. The Column headings on the Chemical Resistance Table, I, II, III, IV, V refer to specific groups of hoses.
4. Locate hose part number under Column I, II, III, IV, V. VI from the list below.
5. For fitting material availability refer to appropriate fitting section of catalogue.
6. Check hose specifications in this catalogue. Contact Hose Products Division Europe Technical Department on any items not catalogued.

Resistance Rating Key

A = Preferred, good to excellent with little or no change in physical properties.

F = Fair, marginal or conditional with noticeable effects on physical properties.

X = Unsuitable, severe effects on physical properties.

~ = No rating, insufficient information.

Numerals

1. For air or gaseous applications above 250 PSI (1,7 MPa), the cover should be pin pricked.
2. Legal and insurance regulations must be considered. Contact HPDE Technical Department for more information.
3. Push-Lok hoses (801, 804, 821, 821FR, 831, 836, 837BM, 837PU, 830M, 838M) are not recommended for any type of fuel.
4. Use 285, 235 or 244 hoses. The compatibility of the system's refrigeration oil with these hoses needs to be evaluated on a case by case basis. Contact HPDE Technical Department for more information. Do not use mineral oil or alkyl benzene refrigeration oils with 244 hose. Chemical compatibility does not imply low permeation.
5. 65 °C (150 °F) maximum.
6. Satisfactory at some concentrations and temperatures, unsatisfactory at others.
7. For phosphate ester fluids use 304, 424, 774, 804 or F42 hoses.
8. Acceptable for flushing hose assemblies.
9. 221FR hose recommended.
10. For dry air applications, hoses with inner tubes from columns IV and V are preferred. See hose specifications for maximum recommended temperatures with air.
11. 100 °C (212 °F) maximum.
12. 121 °C (250 °F) maximum.
13. Hoses for gas application are available from Parker. Please contact the Technical Department for more information about the products as well as the legal application requirements.
14. 70 °C maximum for hoses 801, 837BM, 837PU
15. No rating / insufficient information about chemical compatibility for hoses 801, 837BM, 837PU.

Hose Types

Column I:	201, 225, 601, 701, 721, 721TC, 731, 761, 77C, P35, 781, 791TC, 881, H31, H29, R35, R42, H31TC, H29TC, R35TC, R42TC, H31ST, H29ST, R42ST, H29RH	
Column II:	301TC, 351TC, 371LT, SS25UL, 421WC, 431, 441, 441RH, 451, 451TC, 451ST, 461LT, 463, 471TC, 471ST, 493, 681, 681DB, 772LT, 811	
Column III:	221FR, 301SN, 302, 372, 372RH, 372TC, 402, 412, 412ST, 421RH, 421SN, 422, 462, 462ST, 472TC, 477, 477ST, 492, 492ST, 692, 692Twin, 772TC, 772ST, 782TC, 782ST, 787TC, 792TC, 792ST, 797TC, 821, 831	
Column IV:	206, 213, 226, 266, 293, 426, 436, 611, 611HT, 821FR, 836, 801*, 837BM*, 837PU*	Note: * See Numeral 15,16
Column V:	304, 424, 604, 774, 804, F42 - Special EPDM hose for Phosphoric Ester	
Column VI:	830M, 838M	

Caution: The fluid manufacturer's recommended maximum operating temperature for any specific name-brand fluid should be closely observed by the user. Specific name brand fluids can vary greatly between manufacturers even though they are considered to be from the same family of fluids. Using fluids above the manufacturer's maximum recommended temperature can cause the fluid to break down, creating by-products that can be harmful to elastomers or other materials used in the system. When selecting a hose type, both the fluid manufacturer and hose manufacturer's maximum temperature limit must be taken into consideration, with the lower of the two taking precedence.

Medium	I	II	III	IV	V	VI	STEEL	BRASS	SS
3M FC-75	A	A	A	A 15	A	A	A	A	A
A									
Acetic Acid	X	X	X	A 15	6	X	X	X	A
Acetone	X	X	X	A 15	A	X	A	A	A
Acetylene	X	X	X	X	X	-	-	-	-
AEROSHELL Turbine Oil 500 (See MIL-L-23699)	X	X	F	X	X	-	A	A	A
Air	A, 1, 10	A, 1, 10	A, 1, 10	A, 1, 10	A, 1, 10	A	A	A	A
Air (dry)	X	F, 1, 10	F, 1, 10	A, 1, 10	A, 1, 10	A	A	A	A
Alcohol (Methanol-Ethanol)	F	F	F	A 15	F	-	F	A	A
Ammonia (Anhydrous)	X	X	X	X	X	-	X	X	X
Ammonium Chloride	A	A	A	A 15	A	A	X	X	X
Ammonium Hydroxide	F	F	F	A 15	A	X	F	X	A
Ammonium Nitrate	A	A	A	A 15	A	-	F	X	A
Ammonium Phosphate	A	A	A	A 15	A	-	X	X	F
Ammonium Sulfate	A	A	A	A 15	A	-	F	X	F
Amoco 32 Rykon	X	A	A	F 14	X	A	A	A	A
Ampol PE 46	X	X	X	X	A, 7	F	A	A	A
AMSOIL Synthetic ATF	F	A	A	A 15	X	F	A	A	A
Amyl Alcohol	X	X	X	A 15	F	-	X	A	A
Anderol 495,497,500,750	X	X	X	A 15	X	X	A	A	A
Aniline	X	X	X	A 15	A	X	A	X	A
Animal Fats	X	F	F	A 15	F	-	6	6	A
Aquacent Light, Heavy	X	A	A	X	X	A	A	A	A
Argon	A	A	A	A	A	A	A	A	A
Aromatic 100,150	X	F	F	-	X	F	A	A	A
Arrow 602P	A	A	A	A 14	X	A	A	A	A
Asphalt	X	F	F	F 14	X	A	F	F	A
ASTM #3 Oil	F	F	F	A 15	X	-	A	A	A
ATF-M	F	A	A	A 14	X	A	A	A	A
Automotive Brake Fluid	X	X	X	X	-	X	X	X	X
AW 32,46,68	F	A	A	A 14	X	A	A	A	A
B									
BCF	F	F	F	F 15	-	-	A	A	A
Benz Petraulic 32,46,68,100,150,220,320,460	F	A	A	A 14	X	A	A	A	A
Benzene, Benzol	X	X	X	A 15	X	F	A	A	A
Benzgrind HP 15	-	A	A	A 15	X	-	A	A	A
Benzine	X	X	X	F 15	X	-	A	A	A
Biodegradable Hydraulic Fluid 112B	X	A	A	X	-	-	A	A	A
Biodiesel E20	X	F	X	X	X	X	-	-	-
Biodiesel E100	X	F	X	X	X	X	-	-	-
Biodiesel E60	X	F	X	X	X	X	-	-	-
Biodiesel E80	X	F	X	X	X	X	-	-	-
Borax	F	F	F	A 15	A	-	F	A	A
Boric Acid	A	A	A	X	A	X	X	6	A
Brayco 882	X	A	A	A 15	X	-	A	A	A
Brayco Micronic 745	X	X	A	F 14	X	A	A	A	A
Brayco Micronic 776RP	F	A	A	F 14	X	A	A	A	A
Brayco Micronic 889	X	F	F	-	X	-	A	A	A
Brine	F	F	F	A 15	A	-	X	F	F
Butane		See 2 & 13				F	A	A	A
Butyl Alcohol, Butanol	F	F	F	A 15	F	-	F	F	A
C									
Calcium Chloride	A	A	A	A 15	A	-	F	F	X
Calcium Hydroxide	A	A	A	A 15	A	-	A	A	A

Medium	I	II	III	IV	V	VI	STEEL	BRASS	SS
Calcium Hypochlorite	X	X	X	A 15	A	-	X	F	X
Calibrating Fluid	A	A	A	A 14	X	A	A	A	A
Carbon Dioxide, gas	F	F	F	F 15	6	-	A	A	A
Carbon Disulfide	X	X	X	A 15	X	-	A	F	A
Carbon Monoxide (hot)	F	F	F	A 15	6	-	F	6	A
Carbon Tetrachloride	X	X	X	A 15	X	-	6	6	6
Carbonic Acid	F	F	F	X	F	X	X	X	F
Castor Oil	A	A	A	A 15	A	-	A	A	A
Castrol 5000	X	F	F	A 15	X	X	A	A	A
Cellosolve Acetate	X	X	X	X	A	-	X	X	A
Celluguard	A	A	A	-	A	-	A	A	A
Cellulube 90, 150, 220 300, 550, 1000	X	X	X	-	A	-	A	A	A
Chevron Clarity AW 32, 46, 68	A	A	A	A 14	X	A	A	A	A
Chevron FLO-COOL 180	F	F	F	-	X	-	A	A	A
Chevron FR-8, 10, 13, 20	X	X	X	X	A, 7	F	A	A	A
Chevron Hydraulic Oils AW MV 15, 32, 46, 68, 100	A	A	A	A 14	X	A	A	A	A
Chevron HyJet IV (9)	X	X	X	X	A, 7	F	A	A	A
Citric Acid	F	A	A	X	A	X	X	X	6
Commonwealth EDM 242, 244	A	A	A	-	X	A	A	A	A
CompAir CN300	X	X	X	A 15	X	X	A	A	A
CompAir CS100, 200, 300, 400	X	X	X	A 15	X	X	A	A	A
Coolanol 15, 20, 25, 35, 45	A	A	A	A 15	A	X	A	A	A
Copper Chloride	F	A	A	X	A	-	X	X	X
Copper Sulfate	A	A	A	X	A	-	X	X	F
Cosmolubric HF-122, HF-130, HF-144	X	F	A	X	X	-	A	A	A
Cosmolubric HF-1530	X	F	A	X	X	-	A	A	A
Cottonseed Oil	F	A	A	F 15	X	-	A	A	A
CPI CP-4000	X	X	X	A 15	X	-	A	A	A
Crude Petroleum Oil	F	A	A	A 14	X	A	F	F	A
CSS 1001 Dairy Hydraulic Fluid	F	A	A	A 15	X	-	A	A	A
D									
Daphne AW32	A	A	A	A 14	X	A	A	A	A
Dasco FR 201-A	A	A	A	-	X	-	A	A	A
Dasco FR150, 200, 310	F	A	A	-	A	-	A	A	A
Dasco FR300, FR2550	X	X	X	-	X	F	A	A	A
Dasco FR355-3	X	F	A	X	X	X	A	A	A
Deicer Fluid 419R	A	A	A	-	-	A	A	A	A
Deionized Water	A	A	A	A 15	A	-	F	F	A
Dexron II ATF	F	A	A	A 14	X	A	A	A	A
Dexron III ATF	X	F, 11	F, 11	A 15, 12	X	-	A	A	A
Diesel Fuel	F, 3	A, 3	A, 3	A 15, 3	X	A(2)	A	A	A
Diester Fluids	X	X	X	A 15	X	X	A	A	A
Dow Corning 2-1802 Sullair (24KT)	-	-	-	F 15	-	-	A	A	A
Dow Corning DC 200, 510, 550, 560, FC126	A	A	A	A 15	-	-	A	A	A
Dow HD50-4	F	F	F	-	-	-	-	-	A
Dow Sullube 32	-	-	-	F 15	-	-	A	A	A
Dowtherm A,E	X	X	X	A 15	X	-	A	A	A
Dowtherm G	X	X	X	X	X	-	A	A	A
Duro AW-16, 31	A	A	A	-	X	-	A	A	A
Duro FR-HD	A	A	A	-	X	-	A	A	A
E									
EcoSafe FR-68	A	A	A	-	X	X	A	A	A
Ethanol	F	F	F	A 15	F	-	F	A	A
Ethers	X	X	X	A 15	X	-	A	A	A

Medium	I	II	III	IV	V	VI	STEEL	BRASS	SS
Ethyl Acetate	X	X	X	A 15	F	-	F	A	A
Ethyl Alcohol	F	F	F	A 15	F	-	F	A	A
Ethyl Cellulose	F	F	F	A 15	F	-	X	F	F
Ethyl Chloride	X	X	X	X	A	-	F	F	F
Ethylene Dichloride	X	X	X	A 15	X	-	X	A	X
Ethylene Glycol	F	A	A	A	A	A	A	F	A
Exxon 3110 FR	A	A	A	A 15	X	A	A	A	A
Exxon Esstic	A	A	A	A 14	A	A	A	A	A
Exxon Nuto H 46, 68	A	A	A	A 14	X	A	A	A	A
Exxon Tellura Industrial Process Oils	A	A	A	A 14	X	A	A	A	A
Exxon Terresstic, EP	A	A	A	A 14	A	A	A	A	A
Exxon Turbo Oil 2380	X	F	F	A 15	X	X	A	A	A
Exxon Univolt 60, N61	F	A	A	A 14	X	A	A	A	A
F									
FE 232 (Halon)	X	X	X	X	F	-	A	A	A
Fenso 150	-	A	A	-	X	A	A	A	A
Formaldehyde	X	X	X	A 15	A	-	X	F	A
Formic Acid	X	X	X	X	A	X	X	6	X
Freons see refrigerants	-	-	-	-	-	-	-	-	-
Fuel Oil	F, 3	A, 3	A, 3	A 15, 3	X	A(2)	A	A	A
Fyre-Safe 120C, 126, 155, 1090E, 1150, 1220, 1300E	X	X	X	X	A, 7	F	A	A	A
Fyre-Safe 200C, 225, 211	F	A	A	A	A	F	A	A	A
Fyre-Safe W/O	A	A	A	A 15	X	A	A	A	A
Fyrguard 150, 150-M, 200	A	A	A	A	A	F	A	A	A
Fyrquel 60, 90, 150, 220, 300, 550, 1000	X	X	X	X	A, 7	F	A	A	A
Fyrquel EHC, GT, LT, VPF	X	X	X	X	A, 7	F	A	A	A
Fyrtek MF, 215, 290, 295	X	X	X	X	X	F	A	A	A
G									
Gardner-Denver GD5000, GD8000	X	X	X	A 15	X	X	A	A	A
Gasoline		See 9				-	A	A	A
Glue	F	F	F	-	X	-	A	F	A
Glycerine, Glycerol	A	A	A	A 15	A	-	A	F	A
Grease	A	A	A	A 14	X	A	A	A	A
Gulf-FR Fluid P37, P40, P43, P45, P47	X	X	X	A 15	A	-	A	A	A
H									
H-515 (NATO)	A	A	A	-	X	-	A	A	A
Halon 1211, 1301	F	F	F	F 15	-	-	A	A	A
Helium Gas	X	X	X	X	X	-	A	A	A
Heptane	X	F	F	A 15	X	-	A	A	A
Hexane	X	F	F	A 15	X	-	A	A	A
HF-20, HF-28		A	A	A	A	F	A	A	A
Houghto-Safe 1055, 1110, 1115, 1120, 1130 (9)	X	X	X	X	A, 7	F	A	A	A
Houghto-Safe 271 to 640	F	A	A	A	A	F	A	A	A
Houghto-Safe 419 Hydraulic Fluid	A	A	A	-	X	-	A	A	A
Houghto-Safe 419R Deicer Fluid	A	A	A	-	-	A	A	A	A
Houghto-Safe 5046, 5046W, 5047-F	A	A	A	A 15	X	-	A	A	A
HP 100C (Jack hammer oil)	F	A	A	A 14	X	A	A	A	A
HPWG 46B	F	A	A	A	-	F	A	A	A
Hul-E-Mul	A	A	A	-	X	-	A	A	A
Hychem C, EP1000, RDF	A	A	A	A 15	A	-	A	A	A
Hydra Safe E-190	A	A	A	A 15	X	-	A	A	A
Hydra-Cut 481, 496	A	A	A	-	X	-	A	A	A
Hydrafluid 760	A	A	A	-	X	-	A	A	A
Hydrochloric Acid	X	X	X	X	X	X	X	X	X

Medium	I	II	III	IV	V	VI	STEEL	BRASS	SS
Hydrofluoric Acid	X	X	X	X	X	X	X	6	X
Hydrogen Gas	X	X	X	X	X	-	A	A	A
Hydrogen Peroxide	X	X	X	A 15	X	-	X	X	6
Hydrogen Sulfide	X	X	X	X	A	-	X	X	6
Hydrolube	A	A	A	A 15	A	-	A	A	A
Hydrolubric 120-B, 141, 595	F	A	A	A 15	A	-	A	A	A
Hydrosafe Glycol 200	A	A	A	A	A	F	A	F	A
HyJet IV	X	X	X	X	A, 7	-	A	A	A
I									
Ideal Yellow 77	A	A	A	A 15	X	-	A	A	A
Imol S150 to S550	X	X	X	-	-	-	A	A	A
Ingersoll Rand SSR Coolant	X	X	X	A 15	X	X	A	A	A
Isocyanates	X	X	X	A 15	X	-	A	-	A
Isooctane	X	F	F	A 15	X	-	A	A	A
Isopar H	X	X	X	X	X	-	A	A	A
Isopropyl Alcohol	F	F	F	A 15	F	-	F	A	A
J									
Jayflex DIDP	X	X	X	X	A	-	A	A	A
JP3 and JP4	X	A,3	A,3	-	X	A(2)	A	A	A
JP5	X	A,3	A,3	F 15,3	X	A(2)	A	A	A
JP9	X	X	X	X	X	-	A	-	A
K									
Kaeser 150P, 175P, 325R, 687R	X	X	X	A 15	X	-	A	A	A
Kerosene	X	A	A	F 14	X	A	A	A	A
KSL-214, 219, 220, 222	X	X	X	A 15	X	-	A	A	A
L									
Lacquer	X	X	X	A 15	X	-	X	A	A
Lacquer Solvents	X	X	X	A 15	X	-	X	A	A
Lactic Acids	X	X	X	X	X	X	X	X	A
Lindol HF	X	X	X	A 15	A	-	A	A	A
Linseed Oil	A	A	A	A 15	A	-	A	A	A
LP-Gas		See 13				-	A	A	A
M									
Magnesium Chloride	A	A	A	A 15	A	-	X	X	X
Magnesium Hydroxide	F	F	F	A 15	A	-	F	F	F
Magnesium Sulfate	A	A	A	A 15	A	-	A	F	A
Mercaptans	X	X	X	X	X	-	-	-	-
Methane		See 13				-	A	A	A
Methanol	F	F	F	A 15	F	-	F	A	A
Methyl Alcohol	F	F	F	A 15	F	-	F	A	A
Methyl Chloride	X	X	X	A 15	X	-	A	A	A
Methyl Ethyl Ketone (MEK)	X	X	X	A 15	X	-	F	A	A
Methyl Isopropyl-Ketone	X	X	X	X	X	-	F	A	A
Metsafe FR303, FR310, FR315, FR330, FR350	X	X	X	X	X	F	A	A	A
Microzol-T46	X	A	A	-	X	-	A	A	A
MIL-B-46176A	X	X	X	X	X	-	X	X	X
MIL-H-46170	X	F	F	A 15	X	-	A	A	A
MIL-H-5606	F	A	A	A 14	X	A	A	A	A
MIL-H-6083	F	A	A	A 15	X	-	A	A	A
MIL-H-7083	F	A	A	A 15	X	-	A	A	A
MIL-H-83282	F	A	A	A 15	X	-	A	A	A
MIL-L-2104, 2104B	F	A	A	A 14	X	A	A	A	A
MIL-L-23699	X	X	X	X	X	X	A	A	A
MIL-L-7808	F	A	A	-	X	-	A	A	A

Medium	I	II	III	IV	V	VI	STEEL	BRASS	SS
Mine Guard FR	A	A	A	-	A	-	A	A	A
Mineral Oil	A	A	A	F 14	X	A	A	A	A
Mineral Spirits	8	8	8	8	X	-	A	A	A
Mobil Aero HFE	F	A	A	F 14	X	A	A	A	A
Mobil DTE 11M, 13M, 15M, 16M, 18M, 19M	F	A	A	A 14	X	A	A	A	A
Mobil DTE 22, 24, 25, 26	F	A	A	A 14	X	A	A	A	A
Mobil EAL 224H	X	A	A	X	-	-	A	A	A
Mobil EAL Artic 10, 15, 22,32, 46, 68, 100	X	X	X	X	X	X	A	A	A
Mobil Glygoyle 11, 22, 30, 80	A	A	A	-	X	-	A	A	A
Mobil HFA	F	A	A	A 15	X	-	A	A	A
Mobil Jet 2	X	F	F	A 15	X	-	A	A	A
Mobil Nyvac 20, 30, 200, FR	F	A	A	A	A	F	A	A	A
Mobil Rarus 824, 826, 827	X	X	X	A 15	X	X	A	A	A
Mobil SHC 600 Series	F	A	A	A 15	X	-	A	A	A
Mobil SHC 800 Series	F	A	A	A 15	X	-	A	A	A
Mobil SHL 624	-	A	A	A 15	X	-	A	A	A
Mobil Vactra Oil	A	A	A	F 14	X	A	A	A	A
Mobil XRL 1618B	X	X	X	X	A, 7	F	A	A	A
Mobilfluid 423	F	A	A	A 14	X	A	A	A	A
Mobilgear SHC 150, 220, 320, 460, 680	F	F	F	A 15	X	-	A	A	A
Mobilrama 525	A	A	A	F 14	X	A	A	A	A
Molub-Alloy 890	X	X	X	A 15	X	-	A	A	A
Moly Lube "HF" 902	F	F	F	F 14	X	A	A	A	A
Monolec 6120 Hydraulic Oil	A	A	A	A 14	X	A	A	A	A
Morpholine (pure additive)	X	X	X	X	X	-	X	X	A
N									
Naptha	X	F	F	A 15	X	-	A	A	A
Napthalene	X	X	X	A 15	X	-	A	A	A
Natural Gas		See 13				-	A	A	A
Nitric Acid	X	X	X	X	X	X	X	X	F
Nitrobenzene	X	X	X	A 15	X	-	X	X	A
Nitrogen, gas	F, 1	F, 1	F, 1	F 15, 1	F, 1	-	A	A	A
NORPAR 12, 13, 15	8	8	8	8	X	-	A	A	A
Nuto H 46, 68	A	A	A	A 14	X	A	A	A	A
Nyvac 20, 30, 200, FR	F	A	A	A	A	F	A	A	A
Nyvac Light	X	X	X	-	A	-	A	A	A
O									
Oceanic HW	F	A	A	A	X	F	A	A	A
Oxygen, gas	X	X	X	X	X	-	X	A	A
Ozone	F	F	F	-	A	-	A	A	A
P									
Pacer SLC 150, 300, 500, 700	X	X	X	A 15	X	-	A	A	A
Pennzbell AWX	F	A	A	F 14	X	A	A	A	A
PENTOSIN CHF 11S	F	A	A	F	A	X	A	A	A
Perchloroethylene	X	X	X	X	X	-	F	X	A
Petroleum Ether	X	F	F	F 14	X	A	A	A	A
Petroleum Oils	A	A	A	A 14	X	A	A	A	A
Phenol (Carbolic Acid)	X	X	X	A 15	X	X	X	F	A
Phosphate Ester Blends	X	X	X	X	X	F	A	A	A
Phosphate Esters	X	X	X	X	A, 7	-	A	A	A
Phosphoric Acid	X	X	X	X	X	X	X	X	F
Plurasafe P 1000, 1200	F	A	A	A	F	F	A	A	A
Polyalkylene Glycol	A	F	F	-	X	-	A	A	A
Polyol Ester	X	F	A	X	X	-	A	A	A

Medium	I	II	III	IV	V	VI	STEEL	BRASS	SS
Potassium Chloride	A	A	A	A 15	A	-	X	F	F
Potassium Hydroxide	X	X	X	A 15	A	-	6	X	A
Potassium Sulfate	A	A	A	A 15	A	-	A	A	A
Propane		See 13				-	A	A	A
Propylene Glycol	F	A	A	A 15	A	-	F	F	F
Pydraul 10-E, 29-E, 50-E, 65-E, 90-E, 115-E	X	X	X	X	A, 7	F	A	A	A
Pydraul 230-C, 312-C, 68-S	X	X	X	X	A, 7	F	A	A	A
Pydraul 60, 150, 625, F9	X	X	X	X	A, 7	-	A	A	A
Pydraul 90, 135, 230, 312, 540, MC	X	X	X	X	X	-	A	A	A
Pydraul A-200	X	X	X	A 15	X	-	A	A	A
Pyro Gard 43, 230, 630	X	X	X	X	X	-	A	A	A
Pyro Gard C, D, R, 40S, 40W	F	A	A	F 15	X	A	A	A	A
Pyro Guard 53, 55, 51, 42	X	X	X	X	A, 7	-	A	A	A
Q									
Quintolubric 700	A	A	A	A 15	A	-	A	F	A
Quintolubric 807-SN	F	A	A	-	X	-	A	A	A
Quintolubric 822, 833	X	F, 5	A, 5	X	X	X	A	A	A
Quintolubric 822-68EHC (71°C, 160°F maximum)	X	F, 5	A, 5	-	-	-	A	A	A
Quintolubric 888	X	F, 5	A, 5	X	X	-	A	A	A
Quintolubric 957, 958	F	A	A	A	A	F	A	A	A
Quintolubric N822-300	~	~	A	-	-	-	A	A	A
Quintolubric N888	X	A	F	X	-	X	A	A	A
R									
Rando	A	A	A	A 14	X	A	A	A	A
Rayco 782	X	F	A	X	X	-	X	X	X
Refrigerant 124		See 4				X	A	A	A
Refrigerant Freon 113, 114	X	X	X	X	X	X	A	A	A
Refrigerant Freon 12		See 4		X		X	A	A	A
Refrigerant Freon 22		See 4		X		X	A	A	A
Refrigerant Freon 502		See 4		X		X	A	A	A
Refrigerant HFC134A		See 4		X		X	A	A	A
Reolube Turbofluid 46	X	X	X	X	A, 7	-	A	A	A
Rotella	A	A	A	A 14	X	A	A	A	A
Royal Bio Guard 3032, 3046, 3068, 3100	X	~	A	X	X	X	A	A	A
Royco 2200, 2210, 2222, 2232, 2246, 2268	X	X	X	X	X	X	A	A	A
Royco 4032, 4068, 4100, 4150	X	X	X	A 15	X	X	A	A	A
Royco 756, 783	A	A	A	A 14	X	A	A	A	A
Royco 770	X	F	F	F 15	X	-	A	A	A
RTV Silicone Adhesive Sealants	X	X	X	X	X	-	A	A	A
S									
Safco-Safe T10, T20	-	-	-	-	A	-	F	F	A
Safety-Kleen ISO 32, 46, 68 hydraulic oil	F	A	A	-	X	A	A	A	A
Safety-Kleen Solvent	8	8	8	8	X	-	A	A	A
Santoflex 13	F	F	F	-	F	-	A	A	A
Santosafe 300	X	X	X	-	X	-	A	A	A
Santosafe W/G 15 to 30	-	-	-	A 15	A	-	A	A	A
Sea Water	F	F	F	A 15	A	-	X	F	A
Sewage	F	F	F	A 15	F	-	X	F	A
Shell 140 Solvent	8	8	8	8	X	-	A	A	A
Shell Clavus HFC 68	X	X	X	X	X	X	A	A	A
Shell Comptella Oil	F	F	F	A 14	X	A	A	A	A
Shell Comptella Oil S 46, 68	F	F	F	A 14	X	A	A	A	A
Shell Comptella Oil SM	F	F	F	A 14	X	A	A	A	A
Shell Diala A, (R) Oil AX	F	A	A	F 14	X	A	A	A	A

Medium	I	II	III	IV	V	VI	STEEL	BRASS	SS
Shell FRM	-	-	-	-	X	-	A	A	A
Shell IRUS 902, 905	A	A	A	-	A	-	A	A	A
Shell Naturelle HF-E	F	A	A	F	A	X	A	A	A
Shell Pella-A	A	A	A	A 15	X	-	A	A	A
Shell Tellus	F	A	A	A 14	X	A	A	A	A
Shell Tellus TD 46	A	A	A	A	A	X	A	A	A
Shell Thermia Oil C	A	A	A	A 14	X	A	A	A	A
Shell Turbo R	X	F	F	A 15	X	X	A	A	A
SHF 220, 300, 450	X	X	A	X	X	X	A	A	A
Silicate Esters	A	F	F	A 15	X	-	A	A	A
Silicone Oils	A	A	A	-	-	-	A	A	A
Silicone Sealants	X	X	X	X	X	-	A	A	A
Skydrol 500B-4, LD-4	X	X	X	X	A, 7	F	A	A	A
Soap Solutions	X	F	F	F 15	A	-	A	A	A
Soda Ash, Sodium Carbonate	A	A	A	A 15	A	-	A	F	A
Sodium Bisulfate	F	F	F	A 15	A	-	F	A	F
Sodium Chloride	F	F	F	A 15	A	-	X	F	A
Sodium Hydroxide	X	X	X	A 15	A	-	A	X	A
Sodium Hypochlorite	F	F	F	X	F	-	X	X	X
Sodium Nitrate	F	F	F	A 15	A	-	A	F	A
Sodium Peroxide	X	X	X	X	A	-	X	X	A
Sodium Silicate	A	A	A	A 15	A	-	A	A	A
Sodium Sulfate	A	A	A	A 15	A	-	A	A	A
Soybean Oil	F	A	A	A 15	A	-	A	A	A
SSR Coolant	X	X	X	A 15	X	X	A	A	A
Steam	X	X	X	X	X	-	F	A	A
Stoddard Solvent	8	8	8	8	X	-	A	A	A
Sulfur Chloride	X	X	X	A 15	X	-	X	X	X
Sulfur Dioxide	X	X	X	X	F	-	X	F	F
Sulfur Trioxide	X	X	X	A 15	F	-	X	X	X
Sulfuric Acid (0% to 30% room temperture)	F, 6	F, 6	F, 6	X	F, 6	-	6	X	6
Summa-20, Rotor, Recip	X	X	X	A 15	X	-	A	A	A
Summit DSL-32,68,100,125	X	X	X	A 15	X	-	A	A	A
Sun Minesafe, Sun Safe	X	F	F	A 15	X	-	A	A	A
Sundex 8125	X	F	F	-	A	-	A	A	A
Suniso 3GS	A	A	A	A 14	X	A	A	A	A
Sun-Vis 722	X	F	F	-	X	-	A	A	A
Super Hydraulic Oil 100, 150, 220	A	A	A	A 14	X	A	A	A	A
SUVA MP 39, 52, 66	X	X	X	X	X	X	A	A	A
SYNCON Oil	X	X	X	X	X	-	A	A	A
Syndale 2820	X	F	F	-	-	-	A	A	A
Synesstic 32,68,100	X	X	X	X	X	X	A	A	A
Syn-Flo 70,90	X	X	X	A 15	X	-	A	A	A
SYN-O-AD 8478	X	X	X	X	A, 7	F	A	A	A
T									
Tannic Acid	F	A	A	A 15	A	X	X	F	X
Tar	F	F	F	A 15	X	-	X	F	A
Tellus (Shell)	F	A	A	A 14	X	A	A	A	A
Texaco 760 Hydrafluid	-	-	-	-	X	-	A	A	A
Texaco 766, 763 (200 - 300)	-	-	-	-	A	-	F	F	A
Texaco A-Z Oil	A	A	A	F 14	X	A	A	A	A
Texaco Spindura Oil 22	F	F	F	F 14	X	A	A	A	A
Texaco Way Lubricant 68	A	A	A	A 14	X	A	A	A	A
Thanol-R-650-X	X	F	F	-	X	-	A	A	A

Medium	I	II	III	IV	V	VI	STEEL	BRASS	SS
Thermanol 60	X	X	X	X	X	-	A	A	A
Toluene, Toluol	X	X	X	X	X	-	A	A	A
Transmission Oil	A	A	A	A 14	X	A	A	A	A
Tribol 1440	X	F	F	X	X	F	A	A	A
Trichloroethylene	X	X	X	A 15	X	-	X	A	A
Trim-Sol	F	A	A	A 15	X	-	A	A	A
Turbinol 50, 1122, 1223	X	X	X	X	A, 7	-	A	A	A
Turpentine	X	X	X	A 15	X	-	A	A	A
U									
Ucon Hydrolubes	F	A	A	A	A	F	A	A	A
UltraChem 215,230,501,751	X	X	X	A 15	X	-	A	A	A
Univis J26	A	A	A	A 14	X	A	A	A	A
Unleaded Gasoline		See 9				-	A	A	A
Unocal 66/3 Mineral Spirits	8	8	8	8	X	-	A	A	A
Urea	F	F	F	A 15	F	-	F	-	F
Urethane Formulations	A	A	A	A 15	-	-	A	A	A
V									
Van Straaten 902	A	A	A	A 15	X	-	A	A	A
Varnish	X	X	X	A 15	X	-	F	F	A
Varsol	8	F	F	8	X	-	A	A	A
Versilube F44, F55		A	A	A 15	-	-	A	A	A
Vinegar	X	X	X	A 15	A	-	F	X	A
Vital 29, 4300, 5230, 5310	X	X	X	X	X	-	A	A	A
Volt Esso 35	A	A	A	A 15	X	-	A	A	A
W									
Water	F	A	A	A	A	A	F	A	A
Water / Glycols	A	A	A	A	A	F	A	F	A
X									
Xylene, Xylol	X	X	X	X	X	-	A	A	A
Z									
Zerol 150	A	A	A	A 14	X	A	A	A	A
Zinc Chloride	A	A	A	X	A	-	X	X	F
Zinc Sulfate	A	A	A	X	A	-	X	A	A

Identifying Fitting Types

In general fittings can be identified by their visual appearance, their sealing surface/sealing type or by their thread type/form. Viewing the following pages, the visual identification will be self explanatory. The sealing mechanism and the method of thread identification, however, needs further explanation

Determining Sealing Mechanisms:

- Thread interface
- O-ring
- Matching angle or metal-to-metal joint
- Mated angle with O-ring

Thread Interface

The sealing is assured by the flattening of the edges of the threads when the male is screwed into the female fitting. Typically the front of the male fittings is narrower than the back of the fittings – often referred to as tapered threads.

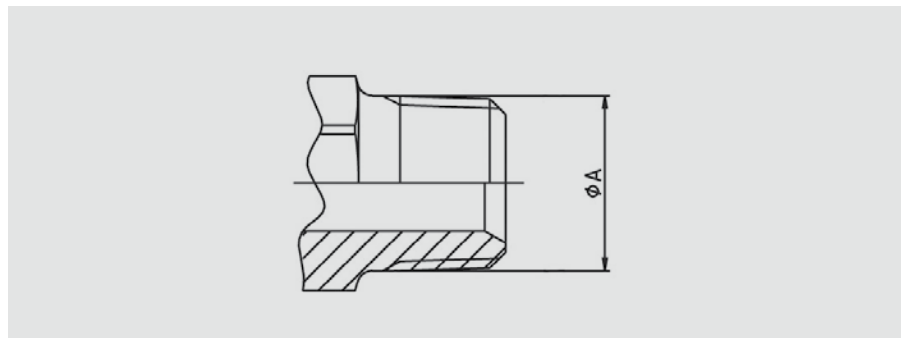

O-ring

The O-ring on the male is compressed against the corresponding female and assures the seal. This type of sealing mechanism should be the preferred choice for high-pressure applications.

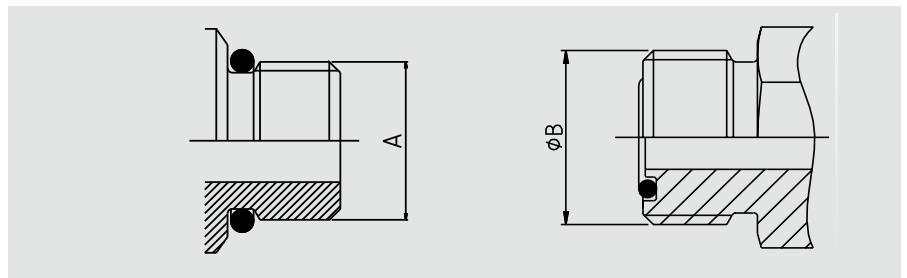

Matching Angle or Metal-to-Metal Joint

Sealing takes place where the two angled faces of the male and corresponding female meet and are wedged into one another by the tightening of the threaded nut. The sealing surfaces can either be convex or concave (seat) on the male or in the head of the pipe of the female as shown.

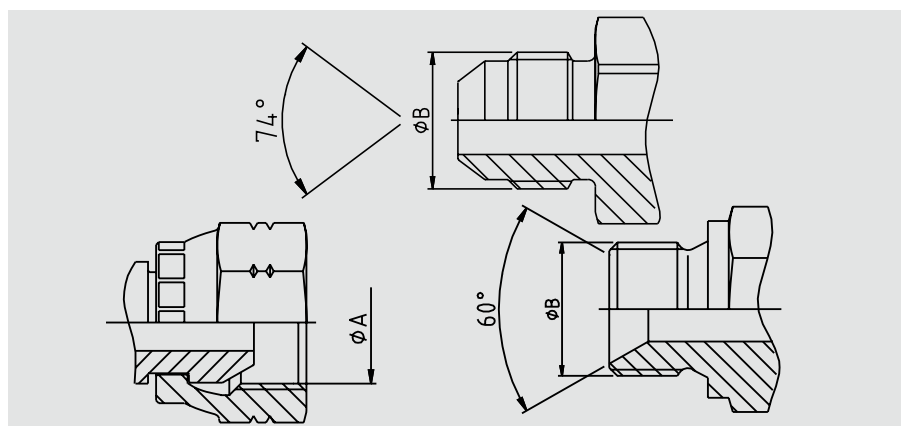

Matching Angle with O-ring

These fittings combine the functionality of both the matching angle seal with the O-ring. The O-ring is in the angled sealing surface of the fitting so that when the threaded male and female are screwed together the sealing surfaces wedge together and at the same time deform the O-ring between them.

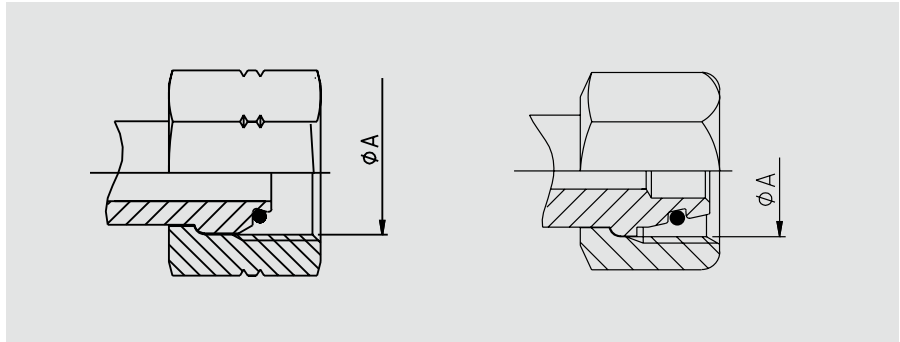

Determining the Thread Type

In general of the threads of various fittings look similar and hinder the easy identification of the thread. To assure the correct identification, the threads must be measured and compared to the tables listed in the following section.

Thread Gauge

Using a thread gauge, the number of threads per inch can be determined. Holding the gauge and coupling threads in front of a lighted background helps to obtain an accurate measurement.

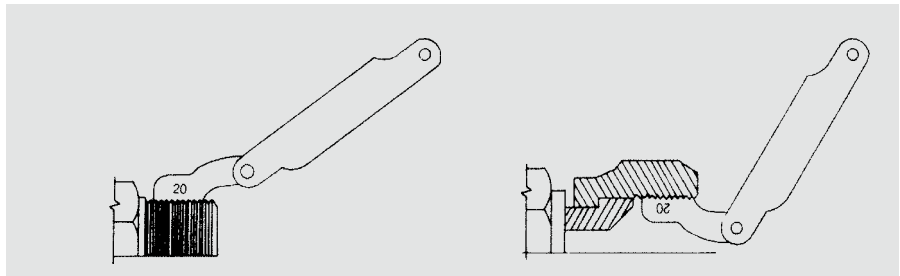

Caliper Measure

A vernier caliper should be used to measure the thread diameter of the largest point. (Outside diameter (O.D.) of male threads – Inside Diameter (I.D.) of female threads.)

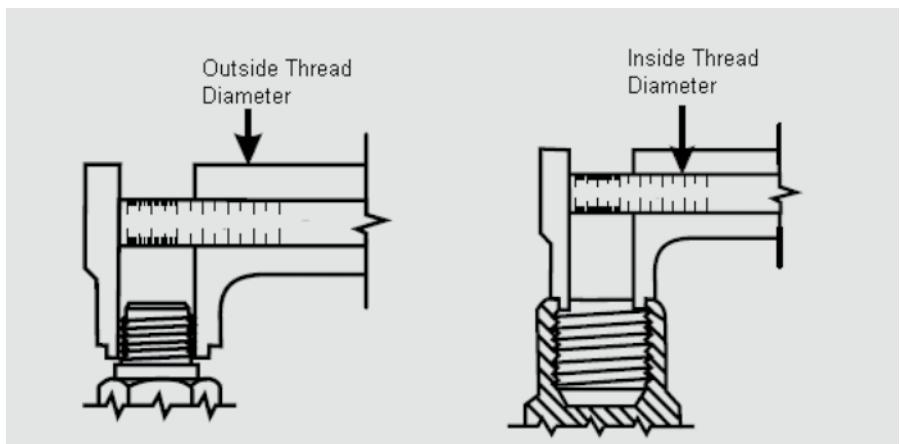

German DIN Hose Fittings

(DIN – Deutsches Institut für Normung)

Often referred to as metric fittings, these fittings seal using the angled sealing surfaces (metal-to-metal) or the combination of metal-to-metal with O-rings.

They are available in **very light (LL)**, **light (L)** or **heavy series (S)**.

The sealing face angles are either 24° with or without O-rings, or 24°/60° universal cones.

Identification is made by measuring the thread size and also the tube outside diameter.

Defined by the outside diameter and the pitch (distance between 2 crests of the thread) example: M22x1.5 - pitch of 1.5mm.



DIN Very Light Series (LL)

The male 60° cone will mate with the female 60° cone only.

The male has a 60° sealing angle (seat) and straight metric thread.

The female has a 60° seat and straight metric thread.

Standard

DIN 20078 Part 3 ¹⁾

Parker end configurations

C0

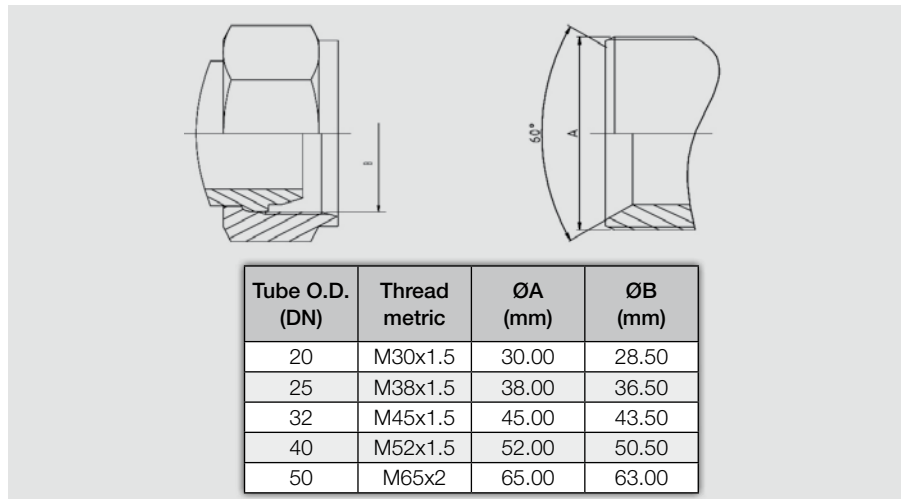

DIN Light (L) and Heavy Series (S) without O-ring

The male 60° cone will mate with the female universal 24° or 60° cone only.

The male has a 60° sealing angle (seat) and straight metric threads.

The female has a 24° and 60° universal seat and straight metric threads.

Standard

DIN 20078 Part 2 ¹⁾

(previously known as DIN 20078 A, D & E)

Parker end configurations

light series

C3, C4, C5, C6

(Often also referred to as “Ball nose cones”)

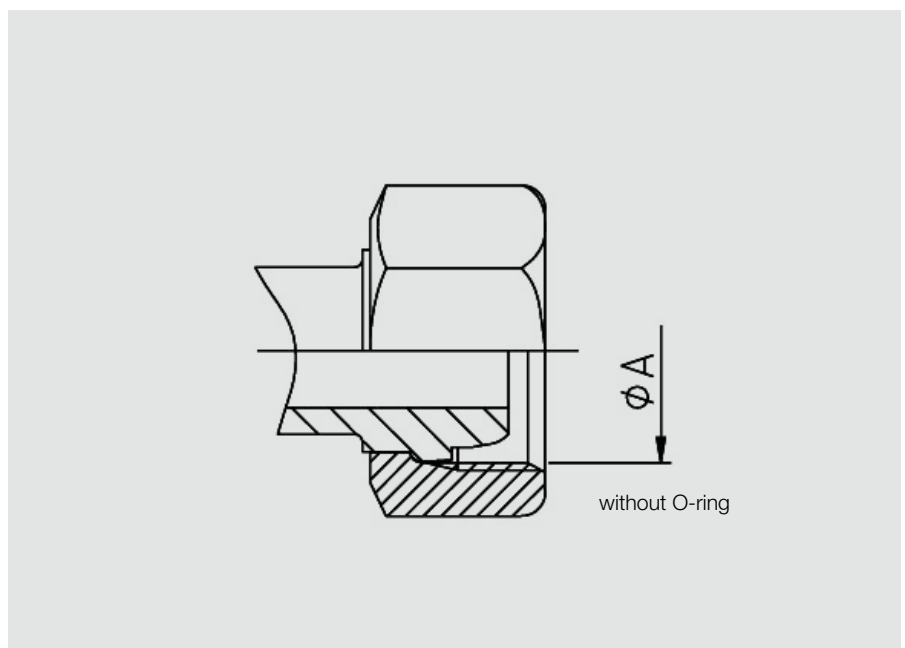

¹⁾ obsolete standard, no exact replacement

DIN 24° Light (L) and Heavy Series (S) with O-ring

The male has a 24° sealing angle cone seat with straight metric threads.

The female has a 24° convex cone with O-ring and a swivel straight metric threaded nut.

Standard

ISO 12151-2 / ISO 8434-1 & ISO 8434-4

(Previously

DIN 20 078 Part 4, 5, 8, 9)

Parker end configurations
light series

CA, CE, CF, D0

Parker end configurations
heavy series

C9, 0C, 1C, D2

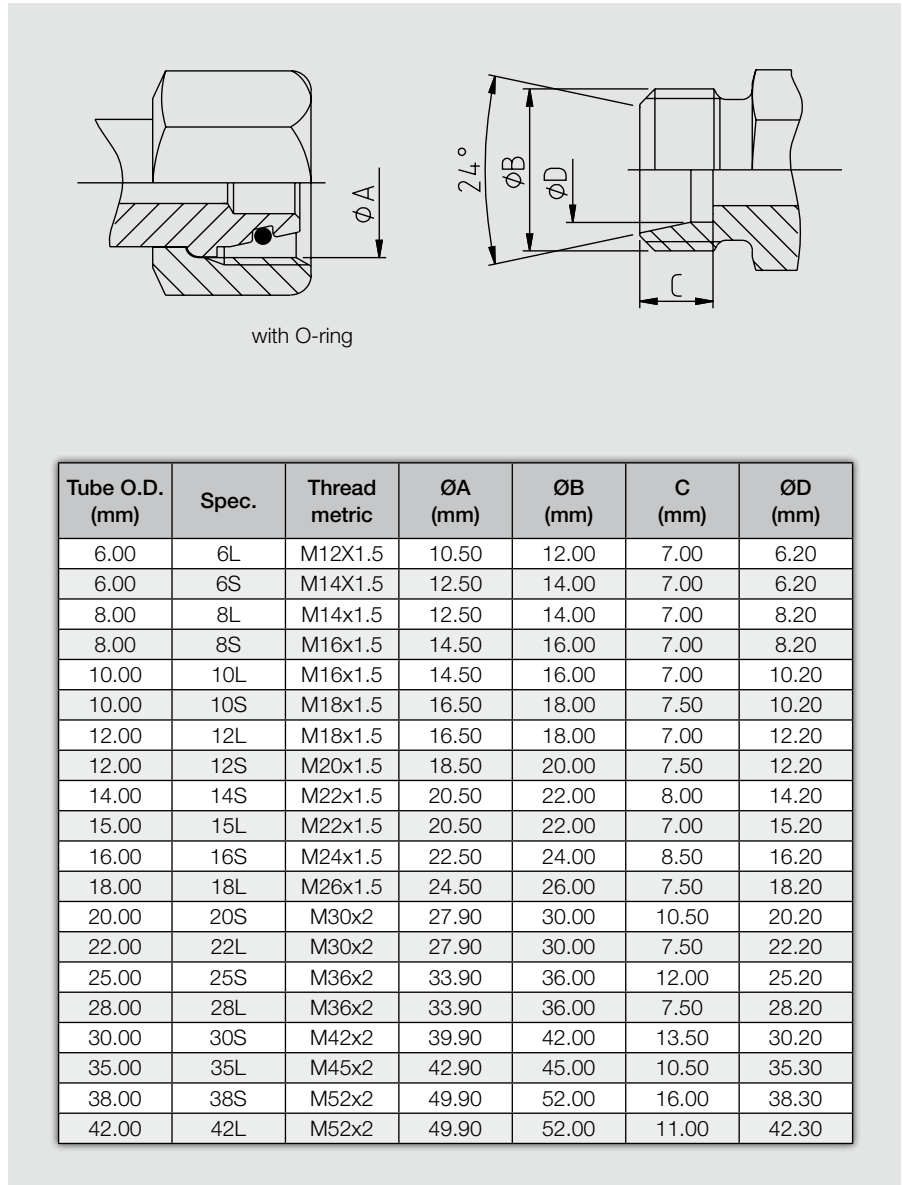

British Standard Pipe (BSP)

Also referred to as Whitworth threads, the BSP thread type fittings seal use metal-to-metal angled surfaces or a combination of metal-to-metal and an O-ring.

The angle of the sealing surfaces is 60° for both forms.

There are two popular thread forms:

British Standard Pipe Parallel (BSPP) and

British Standard Pipe Tapered (BSPT).

Identification is made by measuring the outside diameter of the thread and the number of threads per inch (25.4 mm)

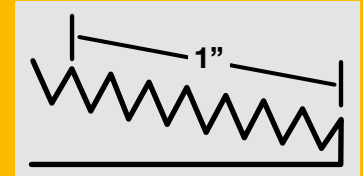

BSPP

metal-to-metal without O-ring
Standard

BS5200

Parker end configurations

92, B1, B2, B4, D9

BSPP

metal-to-metal with O-ring
Standard

ISO 12151-6

Parker end configurations

EA, EB, EC, EE, D9

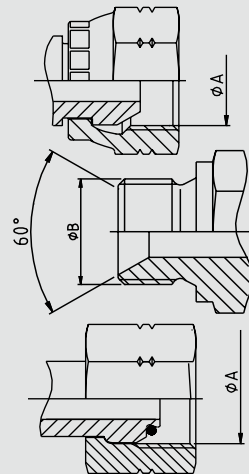

Tube I.D./O.D. (mm)	Size	Thread BSP	ØA (mm)	ØB (mm)
6/10	-2	1/8x28	8.60	9.70
8/13	-4	1/4x19	11.50	13.20
12/17	-6	3/8x19	14.90	16.70
15/21	-8	1/2x14	18.60	20.90
18/23	-10	5/8x14	20.60	22.90
20/27	-12	3/4x14	24.10	26.40
26/34	-16	1x11	30.30	33.20
33/42	-20	1-1/4x11	38.90	41.90
40/49	-24	1-1/2x11	44.90	47.80
50/60	-32	2x11	56.70	59.60

BSPT

fittings seal through the thread interface mechanism. Care should be taken not to confuse the BSPT fitting with the NPTF male fitting. BSPT has a 55° thread angle. NPTF has 60° thread angle.

Parker end configuration

91

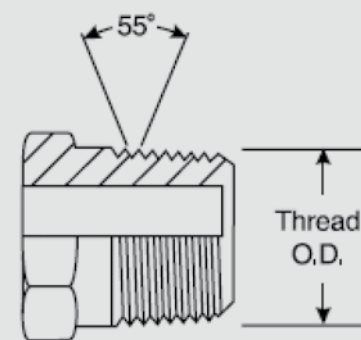

Tube I.D./O.D. (mm)	Size	Thread BSP	ØA (mm)
5/10	-2	1/8x28	9.73
8/13	-4	1/4x19	13.16
12/17	-6	3/8x19	16.66
15/21	-8	1/2x14	20.96
20/27	-12	3/4x14	26.44
26/34	-16	1x11	33.25
33/42	-20	1-1/4x11	41.91
40/49	-24	1-1/2x11	47.80
50/60	-32	2x11	59.61

BSP Flat Seal

These fittings have BSP parallel threads but the sealing surface is flat. The seal is made when the composite seal is compressed against the female flat face.

Parker end configurations

B5, B6, B7

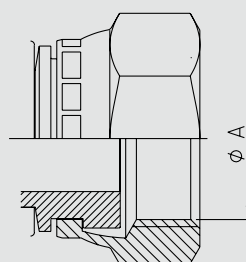

Tube I.D./O.D. (mm)	Size	Thread BSP	ØA (mm)
6/10	-2	1/8x28	8.6
8/13	-4	1/4x19	11.5
12/17	-6	3/8x19	14.9
15/21	-8	1/2x14	18.6
18/23	-10	5/8x14	20.6
20/27	-12	3/4x14	24.1
26/34	-16	1x11	30.3

French Gas fittings

Typical to the French market the French Gas fittings have a 24° sealing surfaces seat with metric straight threads. Although similar to German DIN fittings the threads differ in some sizes as the French Gas fittings have fine threads in all sizes whereas the German DIN fittings use standard threads in the larger sizes.

French Metric 24° Cone Gas Fittings

The sealing mechanism is metal-to-metal.

The fittings are not specified in any international standard.

Parker end configurations

F6, F9 (metric tube)

FG, F2, F4 (gas tube)

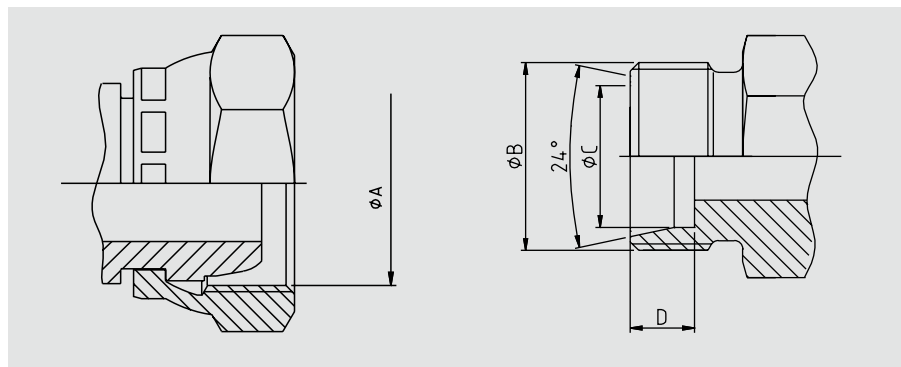

Tube O.D. (mm)	Spec.	Thread metric	ØA (mm)	ØB (mm)	ØC (mm)	D (mm)
6.00	6N	M12x1	11.00	12.00	6.20	9.00
8.00	8N	M14x1.5	12.50	14.00	8.15	9.00
10.00	10N	M16x1.5	14.50	16.00	10.20	9.00
12.00	12N	M18x1.5	16.50	18.00	12.15	9.00
13.25	13G	M20x1.5	18.50	20.00	13.50	9.00
14.00	14N	M20x1.5	18.50	20.00	14.15	9.00
15.00	15N	M22x1.5	20.50	22.00	15.15	9.00
16.00	16N	M24x1.5	22.50	24.00	16.15	9.00
16.75	17G	M24x1.5	22.50	24.00	17.00	9.00
18.00	18N	M27x1.5	25.50	27.00	18.15	9.00
20.00	20N	M27x1.5	25.50	27.00	20.15	9.00
21.25	21G	M30x1.5	28.50	30.00	21.50	9.00
22.00	22N	M30x1.5	28.50	30.00	22.15	9.00
25.00	25N	M33x1.5	31.50	33.00	25.15	9.00
26.75	27G	M36x1.5	34.50	36.00	27.00	9.00
28.00	28N	M36x1.5	34.50	36.00	28.25	9.00
30.00	30N	M39x1.5	37.50	39.00	30.25	9.00
32.00	32N	M42x1.5	40.50	42.00	32.25	9.00
33.25	34G	M45x1.5	43.50	45.00	33.80	9.00
35.00	35N	M45x1.5	43.50	45.00	35.25	9.00
38.00	38N	M48x1.5	46.50	48.00	38.25	9.00
40.00	40N	M52x1.5	50.50	52.00	40.35	9.00
42.25	42G	M52x1.5	50.50	52.00	42.55	9.00
48.25	49G	M58x2	55.90	58.00	49.00	11.00

North American Thread Types

This type of fitting uses the thread interface to seal and as such has a tapered thread that deforms and forms the seal.

They have 30° sealing angle surfaces, forming a 60° inverted (concave) seat.

The fittings are most frequently seen on machines of US origin.

Dryseal American Standard Taper Pipe Thread (NPTF)

The NPTF male will mate with the NPTF, NPSF, or NPSM females.

Care should be taken not to confuse the NPTF fitting with the BSPT male fitting. NPTF fittings have a 60° thread angle.

BSPT has a 55° thread angle.

Standard

SAE J516

Parker end configuration

01

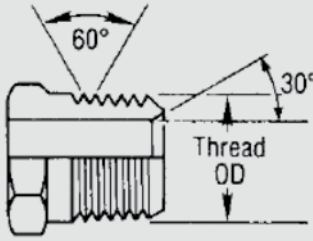

Size	Thread NPTF	ØA (mm)	ØB (mm)
-2	1/8x27	10.24	8.73
-4	1/4x18	13.61	11.90
-6	3/8x18	17.05	15.90
-8	1/2x14	21.22	19.05
-12	3/4x14	26.56	24.60
-16	1x11.5	33.22	30.95
-20	1-1/4x11.5	41.98	39.69
-24	1-1/2x11.5	48.05	45.24
-32	2x11.5	60.09	57.15

ØA dimension is measured on the 4th pitch of the thread

SAE JIC 37°

Commonly referred to as JIC fittings, these metal-to-metal sealing type fittings have a 37° flare (sealing surface angle) and straight United National Fine Threads (UNF).

The original design specification for the fittings comes from the Society of Automotive Engineers (SAE) and these fittings are the most common American fitting types in Europe.

Standard

ISO 12151-5, ISO8434-2 and SAE J516

Parker JIC hose fittings are fully compatible with Parker Triple-Lok Tube Fittings and adapters.

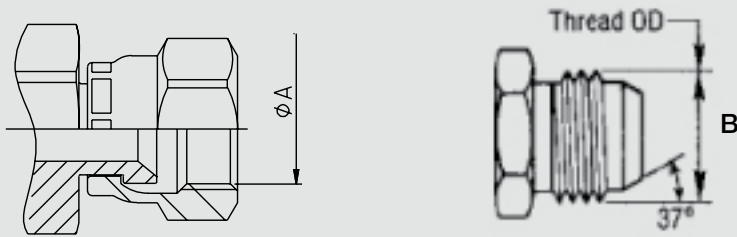

Tube O.D. (inch)	Tube O.D. (mm)	Thread UNF	Size	ØA (mm)	ØB (mm)
3/16		3/8x24	-3	8.60	9.50
1/4	6	7/16x20	-4	10.00	11.10
5/16	8	1/2x20	-5	11.60	12.70
3/8	10	9/16x18	-6	13.00	14.30
1/2	12	3/4x16	-8	17.60	19.10
5/8	14-15-16	7/8x14	-10	20.50	22.20
3/4	18-20	1-1/16x12	-12	24.60	27.00
7/8	22	1-3/16x12	-14	28.30	30.10
1	25	1-5/16x12	-16	31.30	33.30
1-1/4	30-32	1-5/8x12	-20	39.20	41.30
1-1/2	38	1-7/8x12	-24	45.60	47.60
2		2-1/2x12	x32	61.50	63.50

Parker end configurations

03, 06/68, 37/3V, 39/3W, 41/3Y, L9

SAE 45° Flare

The angle of the flare is commonly used as a name when referring to these metal-to-metal sealing fittings.

The female fittings have a 90° concave inverted seat, created by the 45° angle sealing surfaces.

The SAE 45° flare male will mate with an SAE 45° flare female only or a dual seat JIC 37°/SAE45°.

Standard

SAE J516

Parker end configurations

04, 08/68, 77/3V, 79/3W, 81/3Y

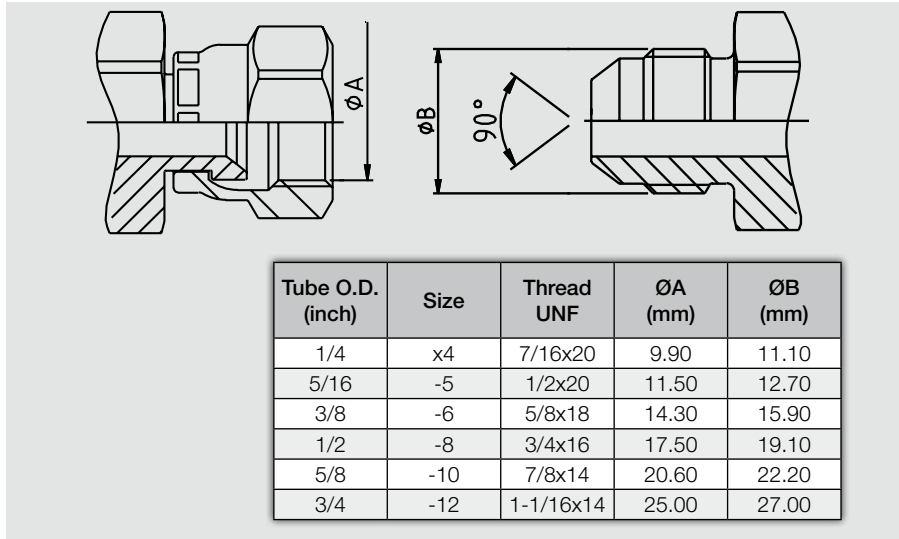

SAE O-ring (Boss Type)

This male fitting has straight threads, a sealing face and an O-ring. It is compatible only with female boss type fittings generally found in the ports of machines.

Sealing is achieved through the O-ring of the male and through the sealing face of the female.

Parker end configuration

05

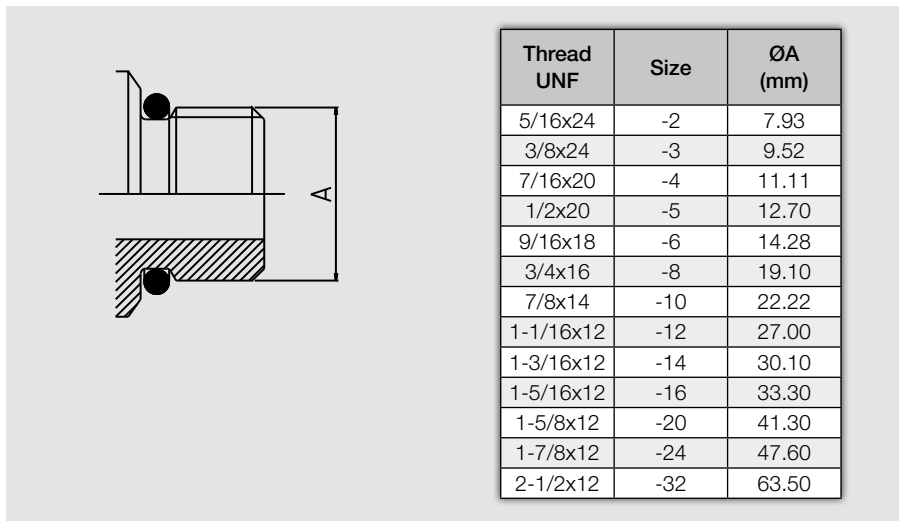

O-ring Face Seal (ORFS)

ORFS fittings are becoming the most popular international fitting type used on global OEM machines due to their high level of sealing and their good vibration resistance. The fittings use the O-ring compression mechanism to seal.

The female fittings have flat faces and straight threaded UNF swivel nuts. The male fittings have the O-ring in a groove in the flat face. Seen as a major advantage, these fittings offer the possibility to build the hose assemblies into fixed distances/spaces, without having to move back other system components due the flat faces of the male and female fittings – the hose assembly can be slotted in.

Standard

ISO 12151-1, ISO8434-3 and

SAE J516

Parker end configurations

JC, JM/J0, JS, JU, J1, J3, J5, J7, J9

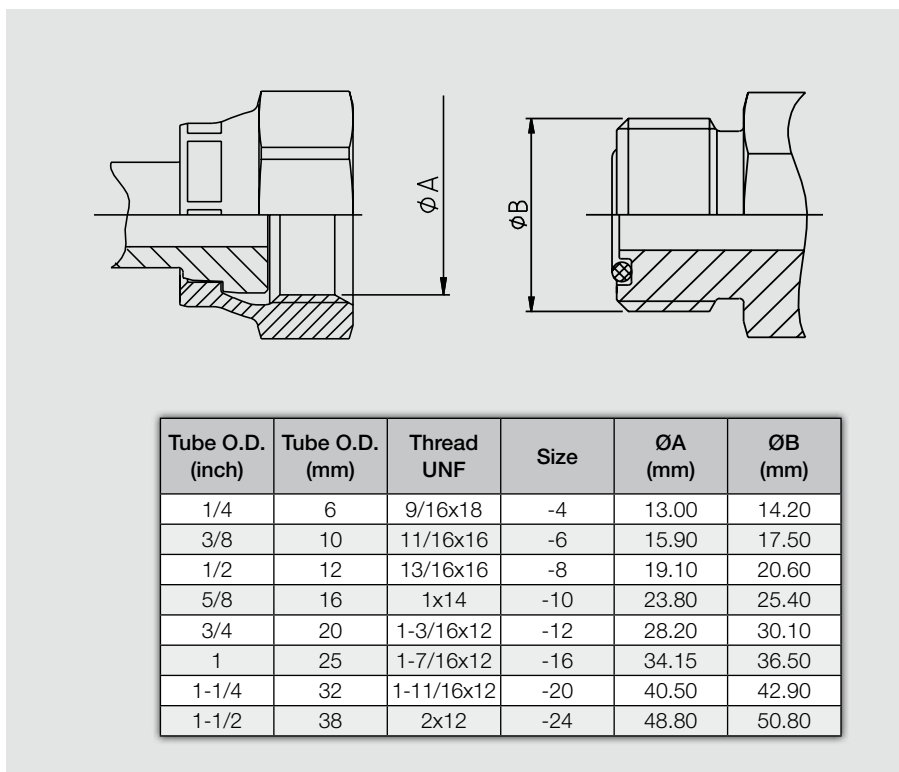

**Flange Fittings
Code 61 and Code 62**

The 4-bolt split flange (or full flange) fitting is used worldwide for connecting high-pressure hoses typically to pumps, motors and cylinders, where the hose assemblies are subjected to large pressure loadings. The sealing mechanism is through compression of the O-ring in the face of the flange head against the surface of the port/connection.

The flange fittings are generally separated into two pressure classes referred to as 3000 psi (SFL) or 6000 psi (SFS). ISO 12151-3 refers to the flange fittings as code 61 for the 3000 psi and code 62 for the 6000 psi. In addition to these flanges, customer-specific Komatsu® and CATERPILLAR® flanges can also be found in the market.

Parker end configurations
Code 61 (3000 psi)
15, 16, 17, 19, P5, P7, P9
5000 psi (Code 61 dimensions)
4A, 4F, 4N
Code 62 (6000 psi)
6A, 6F, 6N, PA, PF, PN, 89
Caterpillar flange
XA, XF, XG, XN

Although not in the SAE or the ISO standard the size -10 (5/8) flange head is gaining popularity. This flange is often found on Komatsu equipment or hydrostatic drives in agricultural machines.

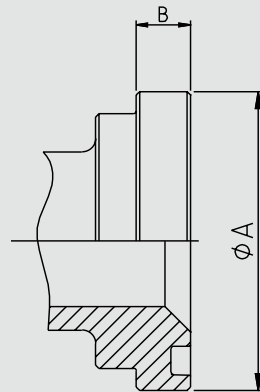

- Standard Code 61 for 3000 to 5000 psi max., depending on size
- High Pressure Code 62 for 6000 psi max. regardless of size

Flange (inch)	Size	Code 61 MPa / psi	Code 62 MPa / psi
1/2	-8	34.5 / 5000	41.3 / 6000
3/4	-12	34.5 / 5000	41.3 / 6000
1	-16	34.5 / 5000	41.3 / 6000
1-1/4	-20	27.5 / 4000	41.3 / 6000
1-1/2	-24	20.7 / 3000	41.3 / 6000
2	-32	20.7 / 3000	41.3 / 6000

Note: 5000 psi in size -20/-24/-32 with 4A,4F and 4N fittings and 50H flange halves.

Code 61 – SAE – 3000 psi

Flange (inch)	Size	ØA (mm)	B (mm)	O-Ring
1/2	-8	30.18	6.73	18.64x3.53
3/4	-12	38.10	6.73	24.99x3.53
1	-16	44.45	8.00	32.92x3.53
1-1/4	-20	50.80	8.00	37.69x3.53
1-1/2	-24	60.33	8.00	47.22x3.53
2	-32	71.42	9.53	56.74x3.53
2-1/2	-40	84.12	9.53	69.44x3.53
3	-48	101.60	9.53	85.32x3.53

Code 62 – SAE – 6000 psi

Flange (inch)	Size	ØA (mm)	B (mm)	O-Ring
1/2	-8	31.75	7.75	18.64x3.53
3/4	-12	41.28	8.76	24.99x3.53
1	-16	47.63	9.53	32.92x3.53
1-1/4	-20	53.98	10.29	37.69x3.53
1-1/2	-24	63.50	12.57	47.22x3.53
2	-32	79.38	12.57	56.74x3.53

CATERPILLAR®

Flange (inch)	Size	ØA (mm)	B (mm)	O-Ring
3/4	-12	41.28	14.22	25.40x5.00
1	-16	47.63	14.22	31.90x5.00
1-1/4	-20	53.98	14.22	38.20x5.00
1-1/2	-24	63.50	14.22	44.70x5.00

Komatsu®

Flange (inch)	Size	ØA (mm)	B (mm)	O-Ring
5/8	-10	34.25	6.00	21.7x3.5

4-Bolt Split Flange

A 4-bolt split flange is used to attach the flange fittings to their ports.

- Standard Code 61 for 3000 to 5000 psi max., depending on size
- High Pressure Code 62 for 6000 psi max., regardless of size

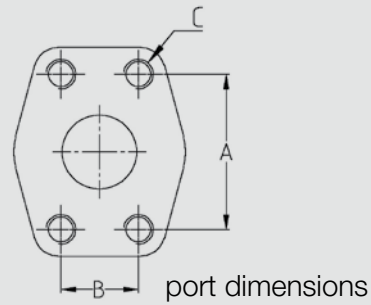

Code 61 – SAE – 3000 psi

Flange (inch)	Size	A (mm)	B (mm)	C	
				(inch)	(metr.)
1/2	-8	38.1	17.5	5/16x18	M8x1.25
3/4	-12	47.6	22.3	3/8x16	M10x1.5
1	-16	52.4	26.2	3/8x16	M10x1.5
1-1/4	-20	58.7	30.2	7/16x14	M10x1.5
1-1/2	-24	69.9	35.7	1/2x13	M12x1.75
2	-32	77.8	42.8	1/2x13	M12x1.75*

Code 62 – SAE – 6000 psi

Flange (inch)	Size	A (mm)	B (mm)	C	
				(inch)	(metr.)
1/2	-8	40.5	18.2	5/16x18	M8x1.25
3/4	-12	50.8	23.8	3/8x16	M10x1.5
1	-16	57.2	27.8	7/16x14	M12x1.75
1-1/4	-20	66.7	31.8	1/2x13	M12x1.75*
1-1/2	-24	79.4	36.5	5/8x11	M16x2
2	-32	96.8	44.4	3/4x10	M20x2.5

*M14x2 still used in the market but no longer in accordance with ISO 6162

Japanese fittings

The Japanese Industrial Standard (JIS) is seen on most Japanese equipment and uses a 30° sealing angle seat and either British Standard Pipe Parallel or metric threads.

Care must be taken not to confuse the JIS fittings with BSP or JIC fittings.

Japanese fittings - JIS

The sealing mechanism of the fittings is the 30° metal-to-metal angled surfaces

Parker end configurations

MU, XU (Metric)

FU (BSP)

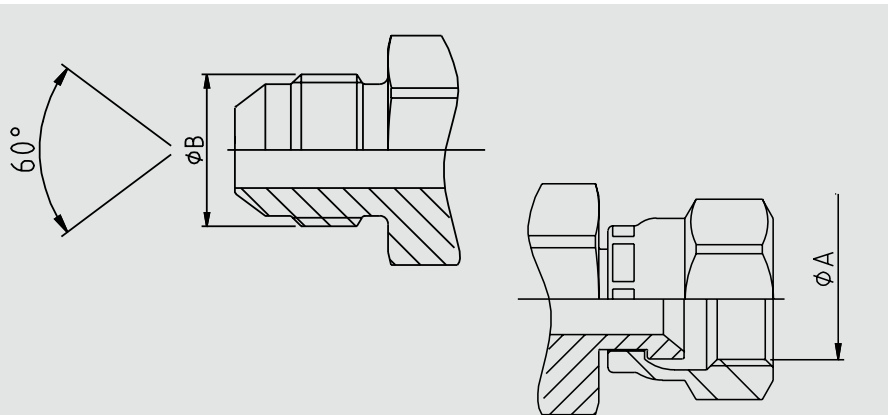

JIS 30° metric

Symbol	Thread metric	ØA (mm)	ØB (mm)
MU-6	M14x1.5	12.50	14.00
MU-9	M18x1.5	16.50	18.00
MU-12	M22x1.5	20.50	22.00
MU-15	M27x2	25.00	27.00
MU-19	M27x2	25.00	27.00
MU-25	M33x2	31.00	33.00
MU-32	M42x2	40.00	42.00
MU-38	M50x2	48.00	50.00
MU-50	M60x2	58.00	60.00

JIS 30° BSP

Symbol	Thread BSP	ØA (mm)	ØB (mm)
GUI-3	1/8x28	8.60	9.70
GUI-5/-6	1/4x19	11.50	13.20
GUI-8/-9	3/8x19	14.90	16.70
GUI-12	1/2x14	18.60	20.90
GUI-15/-19	3/4x14	24.10	26.40
GUI-25	1x11	30.30	33.20
GUI-32	1-1/4x11	38.90	41.90
GUI-38	1-1/2x11	44.90	47.80
GUI-50	2x11	56.70	59.60

Parker Safety Guide for Selecting and Using Hose, Tubing, Fittings and Related Accessories

Parker Publication No. 4400-B.1

Revised: November, 2007



WARNING

Failure or improper selection or improper use of hose, tubing, fittings, assemblies or related accessories ("Products") can cause death, personal injury and property damage. Possible consequences of failure or improper selection or improper use of these Products include but are not limited to:

- Fittings thrown off at high speed.
- High velocity fluid discharge.
- Explosion or burning of the conveyed fluid.
- Electrocution from high voltage electric powerlines.
- Contact with suddenly moving or falling objects that are controlled by the conveyed fluid.
- Injections by high-pressure fluid discharge.
- Dangerously whipping Hose.
- Contact with conveyed fluids that may be hot, cold, toxic or otherwise injurious.
- Sparking or explosion caused by static electricity buildup or other sources of electricity.
- Sparking or explosion while spraying paint or flammable liquids.
- Injuries resulting from inhalation, ingestion or exposure to fluids.

Before selecting or using any of these Products, it is important that you read and follow the instructions below. Only Hose from Parker's Stratoflex Products Division is approved for in flight aerospace applications.

1.0 GENERAL INSTRUCTIONS

1.1 Scope: This safety guide provides instructions for selecting and using (including assembling, installing, and maintaining) these Products. For convenience, all rubber and/or thermoplastic products commonly called "hose" or "tubing" are called "Hose" in this safety guide. All assemblies made with Hose are called "Hose Assemblies". All products commonly called "fittings", "couplings" or "adapters" are called "Fittings". All related accessories (including crimping and swaging machines and tooling) are called "Related Accessories". This safety guide is a supplement to and is to be used with the specific Parker publications for the specific Hose, Fittings and Related Accessories that are being considered for use. Parker publications are available at www.parker.com. SAE J1273 (www.sae.org) and ISO 17165 2 (www.ansi.org) also provide recommended practices for hydraulic Hose Assemblies.

1.2 Fail-Safe: Hose, Hose Assemblies and Fittings can and do fail without warning for many reasons. Design all systems and equipment in a fail safe mode, so that failure of the Hose, Hose Assembly or Fitting will not endanger persons or property.

1.3 Distribution: Provide a copy of this safety guide to each person responsible for selecting or using Hose and Fitting products. Do not select or use Parker Hose or Fittings without thoroughly reading and understanding this safety guide as well as the specific Parker publications for the Products.

1.4 User Responsibility: Due to the wide variety of operating conditions and applications for Hose and Fittings, Parker does not represent or warrant that any particular Hose or Fitting is suitable for any specific end use system. This safety guide does not analyze all technical parameters that must be considered in selecting a product. The user, through its own analysis and testing, is solely responsible for:

- Making the final selection of the Products.
- Assuring that the user's requirements are met and that the application presents no health or safety hazards.
- Providing all appropriate health and safety warnings on the equipment on which the Products are used.
- Assuring compliance with all applicable government and industry standards.

1.5 Additional Questions: Call the appropriate Parker technical service department if you have any questions or require any

additional information. See the Parker publication for the Products being considered or used, or call 1 800 CPARKER, or go to www.parker.com, for telephone numbers of the appropriate technical service department.

2.0 HOSE AND FITTING SELECTION INSTRUCTIONS

2.1 Electrical Conductivity: Certain applications require that the Hose be nonconductive to prevent electrical current flow. Other applications require the Hose and the Fittings and the Hose/Fitting interface to be sufficiently conductive to drain off static electricity. Extreme care must be exercised when selecting Hose and Fittings for these or any other applications in which electrical conductivity or nonconductivity is a factor. The electrical conductivity or nonconductivity of Hose and Fittings is dependent upon many factors and may be susceptible to change. These factors include but are not limited to the various materials used to make the Hose and the Fittings, Fitting finish (some Fitting finishes are electrically conductive while others are nonconductive), manufacturing methods (including moisture control), how the Fittings contact the Hose, age and amount of deterioration or damage or other changes, moisture content of the Hose at any particular time, and other factors. The following are considerations for electrically nonconductive and conductive Hose. For other applications consult the individual catalog pages and the appropriate industry or regulatory standards for proper selection.

2.1.1 Electrically Nonconductive Hose: Certain applications require that the Hose be nonconductive to prevent electrical current flow or to maintain electrical isolation. For applications that require Hose to be electrically nonconductive, including but not limited to applications near high voltage electric lines, only special nonconductive Hose can be used. The manufacturer of the equipment in which the nonconductive Hose is to be used must be consulted to be certain that the Hose and Fittings that are selected are proper for the application. Do not use any Parker Hose or Fittings for any such application requiring nonconductive Hose, including but not limited to applications near high voltage electric lines, unless (i) the application is expressly approved in the Parker technical publication for the product, (ii) the Hose is marked "nonconductive", and (iii) the manufacturer of the equipment on which the Hose is to be used specifically approves the particular Parker Hose and Fittings for such use.

2.1.2 Electrically Conductive Hose: Parker manufactures special Hose for certain applications that require electrically conductive

Hose. Parker manufactures special Hose for conveying paint in airless paint spraying applications. This Hose is labeled “Electrically Conductive Airless Paint Spray Hose” on its layline and packaging. This Hose must be properly connected to the appropriate Parker Fittings and properly grounded in order to dissipate dangerous static charge buildup, which occurs in all airless paint spraying applications. Do not use any other Hose for airless paint spraying, even if electrically conductive. Use of any other Hose or failure to properly connect the Hose can cause a fire or an explosion resulting in death, personal injury, and property damage. Parker manufactures a special Hose for certain compressed natural gas (“CNG”) applications where static electricity buildup may occur. Parker CNG Hose assemblies comply with the requirements of ANSI/IAS NGV 4.2-1999; CSA 12.52-M99, “Hoses for Natural Gas Vehicles and Dispensing Systems” (www.ansi.org). This Hose is labeled “Electrically Conductive for CNG Use” on its layline and packaging. This Hose must be properly connected to the appropriate Parker Fittings and properly grounded in order to dissipate dangerous static charge buildup, which occurs in, for example, high velocity CNG dispensing or transfer. Do not use any other Hose for CNG applications where static charge buildup may occur, even if electrically conductive. Use of other Hoses in CNG applications or failure to properly connect or ground this Hose can cause a fire or an explosion resulting in death, personal injury, and property damage. Care must also be taken to protect against CNG permeation through the Hose wall. See section 2.6, Permeation, for more information. Parker CNG Hose is intended for dispenser and vehicle use at a maximum temperature of 180°F (82°C). Parker CNG Hose should not be used in confined spaces or unventilated areas or areas exceeding 180°F (82°C). Final assemblies must be tested for leaks. CNG Hose Assemblies should be tested on a monthly basis for conductivity per ANSI/IAS NGV 4.2-1999; CSA 12.52-M99. Parker manufactures special Hose for aerospace in flight applications. Aerospace in flight applications employing Hose to transmit fuel, lubricating fluids and hydraulic fluids require a special Hose with a conductive inner tube. This Hose for in flight applications is available only from Parker’s Stratoflex Products Division. Do not use any other Parker Hose for in flight applications, even if electrically conductive. Use of other Hoses for in flight applications or failure to properly connect or ground this Hose can cause a fire or an explosion resulting in death, personal injury and property damage. These Hose assemblies for in flight applications must meet all applicable aerospace industry, aircraft engine and aircraft requirements.

2.2 Pressure: Hose selection must be made so that the published maximum working pressure of the Hose and Fittings are equal to or greater than the maximum system pressure. The maximum working pressure of a Hose Assembly is the lower of the respective published maximum working pressures of the Hose and the Fittings used. Surge pressures or peak transient pressures in the system must be below the published maximum working pressure for the Hose. Surge pressures and peak pressures can usually only be determined by sensitive electrical instrumentation that measures and indicates pressures at millisecond intervals. Mechanical pressure gauges indicate only average pressures and cannot be used to determine surge pressures or peak transient pressures. Published burst pressure ratings for Hose is for manufacturing test purposes only and is no indication that the Product can be used in applications at the burst pressure or otherwise above the published maximum recommended working pressure.

2.3 Suction: Hoses used for suction applications must be selected to ensure that the Hose will withstand the vacuum and pressure of the system. Improperly selected Hose may collapse in suction application.

2.4 Temperature: Be certain that fluid and ambient temperatures, both steady and transient, do not exceed the limitations of the Hose. Temperatures below and above the recommended limit can degrade Hose to a point where a failure may occur and

release fluid. Properly insulate and protect the Hose Assembly when routing near hot objects (e.g. manifolds). Do not use any Hose in any application where failure of the Hose could result in the conveyed fluids (or vapors or mist from the conveyed fluids) contacting any open flame, molten metal, or other potential fire ignition source that could cause burning or explosion of the conveyed fluids or vapors.

2.5 Fluid Compatibility: Hose Assembly selection must assure compatibility of the Hose tube, cover, reinforcement, and Fittings with the fluid media used. See the fluid compatibility chart in the Parker publication for the product being considered or used. This information is offered only as a guide. Actual service life can only be determined by the end user by testing under all extreme conditions and other analysis. Hose that is chemically compatible with a particular fluid must be assembled using Fittings and adapters containing likewise compatible seals.

2.6 Permeation: Permeation (that is, seepage through the Hose) will occur from inside the Hose to outside when Hose is used with gases, liquid and gas fuels, and refrigerants (including but not limited to such materials as helium, diesel fuel, gasoline, natural gas, or LPG). This permeation may result in high concentrations of vapors which are potentially flammable, explosive, or toxic, and in loss of fluid. Dangerous explosions, fires, and other hazards can result when using the wrong Hose for such applications. The system designer must take into account the fact that this permeation will take place and must not use Hose if this permeation could be hazardous. The system designer must take into account all legal, government, insurance, or any other special regulations which govern the use of fuels and refrigerants. Never use a Hose even though the fluid compatibility is acceptable without considering the potential hazardous effects that can result from permeation through the Hose Assembly. Permeation of moisture from outside the Hose to inside the Hose will also occur in Hose assemblies, regardless of internal pressure. If this moisture permeation would have detrimental effects (particularly, but not limited to refrigeration and air conditioning systems), incorporation of sufficient drying capacity in the system or other appropriate system safeguards should be selected and used.

2.7 Size: Transmission of power by means of pressurized fluid varies with pressure and rate of flow. The size of the components must be adequate to keep pressure losses to a minimum and avoid damage due to heat generation or excessive fluid velocity.

2.8 Routing: Attention must be given to optimum routing to minimize inherent problems (kinking or flow restriction due to Hose collapse, twisting of the Hose, proximity to hot objects or heat sources). For additional routing recommendations see SAE J1273 and ISO 17165-2. Hose Assemblies have a finite life and if possible, should be installed in a manner that allows for ease of inspection and future replacement. Rubber Hose because of its relative short life, should not be used in residential and commercial buildings for HVAC (heating, ventilating and air conditioning) applications.

2.9 Environment: Care must be taken to ensure that the Hose and Fittings are either compatible with or protected from the environment (that is, surrounding conditions) to which they are exposed. Environmental conditions including but not limited to ultraviolet radiation, sunlight, heat, ozone, moisture, water, salt water, chemicals and air pollutants can cause degradation and premature failure.

2.10 Mechanical Loads: External forces can significantly reduce Hose life or cause failure. Mechanical loads which must be considered include excessive flexing, twist, kinking, tensile or side loads, bend radius, and vibration. Use of swivel type Fittings or adapters may be required to ensure no twist is put into the Hose. Unusual applications may require special testing prior to Hose selection.

2.11 Physical Damage: Care must be taken to protect Hose from wear, snagging, kinking, bending smaller than minimum bend radius and cutting, any of which can cause premature Hose failure.

Any Hose that has been kinked or bent to a radius smaller than the minimum bend radius, and any Hose that has been cut or is cracked or is otherwise damaged should be removed and discarded.

2.12 Proper End Fitting: See instructions 3.2 through 3.5. These recommendations may be substantiated by testing to industry standards such as SAE J517 for hydraulic applications, or MIL-A-5070, AS1339, or AS3517 for Hoses from Parker's Stratoflex Products Division for aerospace applications.

2.13 Length: When establishing a proper Hose length, motion absorption, Hose length changes due to pressure, and Hose and machine tolerances and movement must be considered.

2.14 Specifications and Standards: When selecting Hose and Fittings, government, industry, and Parker specifications and recommendations must be reviewed and followed as applicable.

2.15 Hose Cleanliness: Hose components may vary in cleanliness levels. Care must be taken to ensure that the Hose Assembly selected has an adequate level of cleanliness for the application.

2.16 Fire Resistant Fluids: Some fire resistant fluids that are to be conveyed by Hose require use of the same type of Hose as used with petroleum base fluids. Some such fluids require a special Hose, while a few fluids will not work with any Hose at all. See instructions 2.5 and 1.5. The wrong Hose may fail after a very short service. In addition, all liquids but pure water may burn fiercely under certain conditions, and even pure water leakage may be hazardous.

2.17 Radiant Heat: Hose can be heated to destruction without contact by such nearby items as hot manifolds or molten metal. The same heat source may then initiate a fire. This can occur despite the presence of cool air around the Hose.

2.18 Welding or Brazing: When using a torch or arc welder in close proximity to hydraulic lines, the hydraulic lines should be removed or shielded with appropriate fire resistant materials. Flame or weld spatter could burn through the Hose and possibly ignite escaping fluid resulting in a catastrophic failure. Heating of plated parts, including Hose Fittings and adapters, above 450°F (232°C) such as during welding, brazing or soldering may emit deadly gases.

2.19 Atomic Radiation: Atomic radiation affects all materials used in Hose assemblies. Since the long-term effects may be unknown, do not expose Hose assemblies to atomic radiation.

2.20 Aerospace Applications: The only Hose and Fittings that may be used for in flight aerospace applications are those available from Parker's Stratoflex Products Division. Do not use any other Hose or Fittings for in flight applications. Do not use any Hose or Fittings from Parker's Stratoflex Products Division with any other Hose or Fittings, unless expressly approved in writing by the engineering manager or chief engineer of Stratoflex Products Division and verified by the user's own testing and inspection to aerospace industry standards.

2.21 Unlocking Couplings: Ball locking couplings or other Fittings with quick disconnect ability can unintentionally disconnect if they are dragged over obstructions, or if the sleeve or other disconnect member, is bumped or moved enough to cause disconnect. Threaded Fittings should be considered where there is a potential for accidental uncoupling.

3.0 HOSE AND FITTING ASSEMBLY AND INSTALLATION INSTRUCTIONS

3.1 Component Inspection: Prior to assembly, a careful examination of the Hose and Fittings must be performed. All components must be checked for correct style, size, catalog number, and length. The Hose must be examined for cleanliness, obstructions, blisters, cover looseness, kinks, cracks, cuts or any other visible defects. Inspect the Fitting and sealing surfaces for burrs, nicks, corrosion or other imperfections. Do NOT use any component that displays any signs of nonconformance.

3.2 Hose and Fitting Assembly: Do not assemble a Parker Fitting on a Parker Hose that is not specifically listed by Parker for that Fitting, unless authorized in writing by the engineering manager or chief engineer of the appropriate Parker division. Do not assemble a Parker Fitting on another manufacturer's Hose or a Parker Hose on another manufacturer's Fitting unless (i) the engineering manager or chief engineer of the appropriate Parker division approves the Assembly in writing or that combination is expressly approved in the appropriate Parker literature for the specific Parker product, and (ii) the user verifies the Assembly and the application through analysis and testing. For Parker Hose that does not specify a Parker Fitting, the user is solely responsible for the selection of the proper Fitting and Hose Assembly procedures. See instruction 1.4. To prevent the possibility of problems such as leakage at the Fitting or system contamination, it is important to completely remove all debris from the cutting operation before installation of the Fittings. The Parker published instructions must be followed for assembling the Fittings on the Hose. These instructions are provided in the Parker Fitting catalog for the specific Parker Fitting being used, or by calling 1 800 CPARKER, or at www.parker.com.

3.3 Related Accessories: Do not crimp or swage any Parker Hose or Fitting with anything but the listed swage or crimp machine and dies in accordance with Parker published instructions. Do not crimp or swage another manufacturer's Fitting with a Parker crimp or swage die unless authorized in writing by the engineering manager or chief engineer of the appropriate Parker division.

3.4 Parts: Do not use any Parker Fitting part (including but not limited to socket, shell, nipple, or insert) except with the correct Parker mating parts, in accordance with Parker published instructions, unless authorized in writing by the engineering manager or chief engineer of the appropriate Parker division.

3.5 Field Attachable/Permanent: Do not reuse any field attachable Hose Fitting that has blown or pulled off a Hose. Do not reuse a Parker permanent Hose Fitting (crimped or swaged) or any part thereof. Complete Hose Assemblies may only be reused after proper inspection under section 4.0. Do not assemble Fittings to any previously used hydraulic Hose that was in service, for use in a fluid power application.

3.6 Pre-Installation Inspection: Prior to installation, a careful examination of the Hose Assembly must be performed. Inspect the Hose Assembly for any damage or defects. DO NOT use any Hose Assembly that displays any signs of nonconformance.

3.7 Minimum Bend Radius: Installation of a Hose at less than the minimum listed bend radius may significantly reduce the Hose life. Particular attention must be given to preclude sharp bending at the Hose to Fitting juncture. Any bending during installation at less than the minimum bend radius must be avoided. If any Hose is kinked during installation, the Hose must be discarded.

3.8 Twist Angle and Orientation: Hose Assembly installation must be such that relative motion of machine components does not produce twisting.

3.9 Securement: In many applications, it may be necessary to restrain, protect, or guide the Hose to protect it from damage by unnecessary flexing, pressure surges, and contact with other mechanical components. Care must be taken to ensure such restraints do not introduce additional stress or wear points.

3.10 Proper Connection of Ports: Proper physical installation of the Hose Assembly requires a correctly installed port connection insuring that no twist or torque is transferred to the Hose when the Fittings are being tightened or otherwise during use..

3.11 External Damage: Proper installation is not complete without insuring that tensile loads, side loads, kinking, flattening, potential abrasion, thread damage or damage to sealing surfaces are corrected or eliminated. See instruction 2.10.

3.12 System Checkout: All air entrapment must be eliminated and the system pressurized to the maximum system pressure (at or below the Hose maximum working pressure) and checked

for proper function and freedom from leaks. Personnel must stay out of potential hazardous areas while testing and using.

3.13 Routing: The Hose Assembly should be routed in such a manner so if a failure does occur, the escaping media will not cause personal injury or property damage. In addition, if fluid media comes in contact with hot surfaces, open flame or sparks, a fire or explosion may occur. See section 2.4.

3.14 Ground Fault Equipment Protection Devices (GFEPDs): **WARNING! Fire and Shock Hazard:** To minimize the danger of fire if the heating cable of a Multitube bundle is damaged or improperly installed, use a Ground Fault Equipment Protection Device. Electrical fault currents may be insufficient to trip a conventional circuit breaker. For ground fault protection, the IEEE 515:1989 (www.ansi.org) standard for heating cables recommends the use of GFEPDs with a nominal 30 milliampere trip level for "piping systems in classified areas, those areas requiring a high degree of maintenance, or which may be exposed to physical abuse or corrosive atmospheres".

4.0 HOSE AND FITTING MAINTENANCE AND REPLACEMENT INSTRUCTIONS

4.1 Even with proper selection and installation, Hose life may be significantly reduced without a continuing maintenance program. The severity of the application, risk potential from a possible Hose failure, and experience with any Hose failures in the application or in similar applications should determine the frequency of the inspection and the replacement for the Products so that Products are replaced before any failure occurs. A maintenance program must be established and followed by the user and, at minimum, must include instructions 4.2 through 4.7.

4.2 Visual Inspection Hose/Fitting: Any of the following conditions require immediate shut down and replacement of the Hose Assembly:

- Fitting slippage on Hose;
- Damaged, cracked, cut or abraded cover (any reinforcement exposed);
- Hard, stiff, heat cracked, or charred Hose;
- Cracked, damaged, or badly corroded Fittings;
- Leaks at Fitting or in Hose;
- Kinked, crushed, flattened or twisted Hose; and
- Blistered, soft, degraded, or loose cover.

4.3 Visual Inspection All Other: The following items must be tightened, repaired, corrected or replaced as required:

- Leaking port conditions;
- Excess dirt buildup;
- Worn clamps, guards or shields; and
- System fluid level, fluid type, and any air entrapment.

4.4 Functional Test: Operate the system at maximum operating pressure and check for possible malfunctions and leaks. Personnel must avoid potential hazardous areas while testing and using the system. See section 2.2.

4.5 Replacement Intervals: Hose assemblies and elastomeric seals used on Hose Fittings and adapters will eventually age, harden, wear and deteriorate under thermal cycling and compression set. Hose Assemblies and elastomeric seals should be inspected and replaced at specific replacement intervals, based on previous service life, government or industry recommendations, or when failures could result in unacceptable downtime, damage, or injury risk. See section 1.2. Hose and Fittings may be subjected to internal mechanical and/or chemical wear from the conveying fluid and may fail without warning. The user must determine the product life under such circumstances by testing. Also see section 2.5. See section 1.2.

4.6 Hose Inspection and Failure: Hydraulic power is accomplished by utilizing high pressure fluids to transfer energy and do work. Hoses, Fittings and Hose Assemblies all contribute to this by transmitting fluids at high pressures. Fluids under pressure can be dangerous and potentially lethal and, therefore, extreme caution must be exercised when working with fluids under pressure and handling the Hoses transporting the fluids. From

time to time, Hose Assemblies will fail if they are not replaced at proper time intervals. Usually these failures are the result of some form of misapplication, abuse, wear or failure to perform proper maintenance. When Hoses fail, generally the high pressure fluids inside escape in a stream which may or may not be visible to the user. Under no circumstances should the user attempt to locate the leak by "feeling" with their hands or any other part of their body. High pressure fluids can and will penetrate the skin and cause severe tissue damage and possibly loss of limb. Even seemingly minor hydraulic fluid injection injuries must be treated immediately by a physician with knowledge of the tissue damaging properties of hydraulic fluid. If a Hose failure occurs, immediately shut down the equipment and leave the area until pressure has been completely released from the Hose Assembly. Simply shutting down the hydraulic pump may or may not eliminate the pressure in the Hose Assembly. Many times check valves, etc., are employed in a system and can cause pressure to remain in a Hose Assembly even when pumps or equipment are not operating. Tiny holes in the Hose, commonly known as pinholes, can eject small, dangerously powerful but hard to see streams of hydraulic fluid. It may take several minutes or even hours for the pressure to be relieved so that the Hose Assembly may be examined safely. Once the pressure has been reduced to zero, the Hose Assembly may be taken off the equipment and examined. It must always be replaced if a failure has occurred. Never attempt to patch or repair a Hose Assembly that has failed. Consult the nearest Parker distributor or the appropriate Parker division for Hose Assembly replacement information. Never touch or examine a failed Hose Assembly unless it is obvious that the Hose no longer contains fluid under pressure. The high pressure fluid is extremely dangerous and can cause serious and potentially fatal injury.

4.7 Elastomeric seals: Elastomeric seals will eventually age, harden, wear and deteriorate under thermal cycling and compression set. Elastomeric seals should be inspected and replaced.

4.8 Refrigerant gases: Special care should be taken when working with refrigeration systems. Sudden escape of refrigerant gases can cause blindness if the escaping gases contact the eye and can cause freezing or other severe injuries if it contacts any other portion of the body.

4.9 Compressed natural gas (CNG): Parker CNG Hose Assemblies should be tested after installation and before use, and at least on a monthly basis per ANSI/IAS NGV 4.2-1999; CSA 12.52-M99 Section 4.2 "Visual Inspection Hose/ Fitting". The recommended procedure is to pressurize the Hose and check for leaks and to visually inspect the Hose for damage. Caution: Matches, candles, open flame or other sources of ignition shall not be used for Hose inspection. Leak check solutions should be rinsed off after use.

5.0 HOSE STORAGE

5.1 Age Control: Hose and Hose Assemblies must be stored in a manner that facilitates age control and first-in and first-out usage based on manufacturing date of the Hose and Hose Assemblies. The shelf life of rubber Hose or Hose Assemblies that have passed visual inspection and a proof test is 10 years (40 quarters) from the date of manufacture. The shelf life of thermoplastic and polytetrafluoroethylene Hose or Hose Assemblies is considered to be unlimited.

5.2 Storage: Stored Hose and Hose Assemblies must not be subjected to damage that could reduce their expected service life and must be placed in a cool, dark and dry area with the ends capped. Stored Hose and Hose Assemblies must not be exposed to temperature extremes, ozone, oils, corrosive liquids or fumes, solvents, high humidity, rodents, insects, ultraviolet light, electromagnetic fields or radioactive materials.

